



ETA-Danmark A/S
Göteborg Plads 1 6
DK-2150 Nordhavn
Tel. +45 72 24 59 00
Fax +45 72 24 59 04
Internet www.etadanmark.dk

Authorized and notified according
to Article 29 of the Regulation (EU)
No 305/2011 of the European
Parliament and of the Council of 9
March 2011

MEMBER OF EOTA



European Technical Assessment ETA-19/0020 of 2022/08/25

General Part

Technical Assessment Body issuing the ETA and designated according to Article 29 of the Regulation (EU) No 305/2011: ETA-Danmark A/S

Trade name of the
construction product:

Eurotec Hold Downs

Product family to which the
above construction product
belongs:

Three-dimensional nailing plate (hold-downs for timber-
to-timber or timber-to-concrete or steel connections)

Manufacturer:

E.u.r.o. Tec GmbH
Unter dem Hofe 5
D-58099 Hagen
Tel. +49 2331 / 6245 - 0
Fax +49 2331 / 6245 - 200
Internet www.eurotec.team

Manufacturing plant:

HSW 34, HSW 43, HSW 44

This European Technical
Assessment contains:

36 pages including 2 annexes which form an integral
part of the document

This European Technical
Assessment is issued in
accordance with Regulation
(EU) No 305/2011, on the
basis of:

EAD 130186-00-0603 for Three-dimensional nailing
plates

This version replaces:

The ETA with the same number issued on 2021-09-01

Translations of this European Technical Assessment in other languages shall fully correspond to the original issued document and should be identified as such.

Communication of this European Technical Assessment, including transmission by electronic means, shall be in full (excepted the confidential Annex(es) referred to above). However, partial reproduction may be made, with the written consent of the issuing Technical Assessment Body. Any partial reproduction has to be identified as such.

II SPECIFIC PART OF THE EUROPEAN TECHNICAL ASSESSMENT

1 Technical description of product

E.u.r.o. Tec hold-downs are one-piece welded or similarly joined face-fixed nailing plates to be used in timber to concrete or to steel or in timber to timber connections.

E.u.r.o. Tec angle brackets, shear angles, shear plates and Tension straps and lifting anchors are one-piece non-welded, face-fixed nailing plates to be used in timber to timber or in timber to concrete or to steel connections. They are connected to construction members made of timber or wood-based products with profiled (ringed shank) nails according to ETA-22/0083 or screws according to ETA-11/0024, bolts according to EN 14592 or Ideefix connectors according to ETA-14/0160 and to concrete or steel members with bolts or metal anchors.

The angle brackets with a steel plate thickness between 2,5 and 4 mm are made from the following materials:

- Hold downs from pre-galvanized steel S355 Fe Zn 12c according to EN 10025
- 3D Hold downs from pre-galvanized steel S250GD / Z275 according to EN 10346
- Shear angles H-H and H-B from pre-galvanized steel S235 Fe Zn 12c according to EN 10025-2
- Angle brackets, shear plates and Tension straps from pre-galvanized steel S250GD / Z275 according to EN 10346
- Base plates from pre-galvanized steel S355 Fe Zn 12c according to EN 10025
- Lifting anchors from steel S235JR according to EN 10025-2

Dimensions, hole positions and typical installations are shown in Annex B. E.u.r.o. Tec hold-downs, angle brackets, shear plates and Tension straps are made from steel with tolerances according to EN 10143.

2 Specification of the intended use in accordance with the applicable European Assessment Document (hereinafter EAD)

The hold-downs, angle brackets, shear angles, shear plates, Tension straps and lifting anchors are intended for use in making connections in load bearing timber structures, as a connection between a beam and a purlin, where requirements for mechanical resistance and stability and safety in use in the sense of the Basic Works Requirements 1 and 4 of Regulation (EU) 305/2011 shall be fulfilled.

The connection may be with a single nailing plate or with nailing plates on one or both sides of the fastened timber member (see Annex B).

The static and kinematical behaviour of the timber members or the supports shall be as described in Annex A and B.

The wood members may be of solid timber, glued laminated timber and similar glued members, or wood-based structural members with a characteristic density from 290 kg/m³ to 460 kg/m³. This requirement to the material of the wood members can be fulfilled by using the following materials:

- Structural solid timber according to EN 14081,
- Glulam according to EN 14080,
- Glued solid timber according to EN 14080,
- LVL according to EN 14374,
- Cross laminated timber according to ETA.

Annex B states the load-carrying capacities of the connections for a characteristic density of 350 kg/m³. For timber or wood based material with a lower or higher characteristic density than 350 kg/m³ the load-carrying capacities shall be reduced or may be increased by the factor k_{dens} :

$$k_{dens} = \left(\frac{\rho_k}{350} \right)^{0.5}$$

where ρ_k is the characteristic density of the timber in kg/m³.

If a wood-based panel interlayer with a thickness of not more than 26 mm is placed between the connector plate and the timber member, the lateral load-carrying capacity of the nail or screw, respectively, has to take into account the effect of the interlayer.

The design of the connections shall be in accordance with Eurocode 5 or a similar national Timber Code. The wood members shall have a thickness which is larger than the penetration depth of the nails or screws into the members.

The nailing plates are primarily for use in timber structures subject to the dry, internal conditions defined by service classes 1 and 2 of Eurocode 5 and for connections subject to static or quasi-static loading.

The nailing plates can also be used in outdoor timber structures, service class 3, when a corrosion protection in accordance with Eurocode 5 is applied, or when stainless steel with similar or better characteristic yield strength and ultimate strength is employed.

The scope of the connectors regarding resistance to corrosion shall be defined according to national

provisions that apply at the installation site considering environmental conditions and in conjunction with the admissible service conditions according to EN 1995-1-1 and the admissible corrosivity category as described and defined in EN ISO 12944-2.

The hold-downs, angle brackets, shear angles, shear plates, Tension straps and lifting anchors may also be used for connections between a timber member and a member of concrete or steel.

Assumed working life

The assumed intended working life of the connectors for the intended use is 50 years, provided that they are subject to appropriate use and maintenance.

The information on the working life should not be regarded as a guarantee provided by the manufacturer or ETA Danmark. An “assumed intended working life” means that it is expected that, when this working life has elapsed, the real working life may be, in normal use conditions, considerably longer without major degradation affecting the essential requirements.

3 Performance of the product and references to the methods used for its assessment

Characteristic	Assessment of characteristic
3.1 Mechanical resistance and stability (BWR 1)*)	
Joint Strength - Characteristic load-carrying capacity	See Annex B
Joint Stiffness	See Annex B
Joint ductility	No performance assessed
Resistance to seismic actions	No performance assessed
Resistance to corrosion and deterioration	See section 3.6
3.2 Safety in case of fire (BWR 2)	
Reaction to fire	The connectors are made from steel classified as Euroclass A1 in accordance with EN 13501-1 and Commission Delegated Regulation 2016/364
3.3 General aspects related to the performance of the product	
	The hold downs have been assessed as having satisfactory durability and serviceability when used in timber structures using the timber species described in Eurocode 5 and subject to the conditions defined by service classes 1 and 2

*) See additional information in section 3.4 – 3.7

3.4 Methods of verification

Safety principles and partial factors

The characteristic load-carrying capacities are based on the characteristic values of the nailed or screwed connections and the steel plates. To obtain design values the capacities have to be divided by different partial factors for the material properties, the nailed or screwed connection in addition multiplied with the coefficient k_{mod} .

According to EN 1990 (Eurocode – Basis of design) paragraph 6.3.5 the design value of load-carrying capacity may be determined by reducing the characteristic values of the load-carrying capacity with different partial factors.

Thus, the characteristic values of the load-carrying capacity are determined also for timber failure $F_{Rk,H}$ (obtaining the embedment strength of fasteners subjected to shear or the withdrawal capacity of the most loaded fastener, respectively) as well as for steel plate failure $F_{Rk,S}$. The design value of the load-carrying capacity is the smaller value of both load-carrying capacities.:

$$F_{Rd} = \min \left\{ \frac{k_{mod} \cdot F_{Rk,T}}{\gamma_{M,T}}; \frac{F_{Rk,S}}{\gamma_{Mi,S}} \right\}$$

Therefore, for timber failure or failure of the metal fasteners the load duration class and the service class are included. The different partial factors γ_M for steel or timber failure, respectively, are also correctly taken into account.

3.5 Mechanical resistance and stability

See annex B for the characteristic load-carrying capacity in the different directions F_1 , F_2 , F_3 , F_4 and F_5

The characteristic capacities of the connectors are determined by calculation assisted by testing as described in the EAD 130186-00-0603 for Three-dimensional nailing plates. They should be used for designs in accordance with Eurocode 5 or a similar national Timber Code.

3.6 Aspects related to the performance of the product

In accordance with EAD 130186-00-0603 for Three-dimensional nailing plates the hold downs are produced from the following materials:

- Hold downs from pre-galvanized steel S355 Fe Zn 12c according to EN 10025
- 3D Hold downs from pre-galvanized steel S250GD / Z275 according to EN 10346
- Shear angles H-H and H-B from pre-galvanized steel S235 Fe Zn 12c according to EN 10025-2
- Angle brackets, shear plates and Tension straps from pre-galvanized steel S250GD / Z275

according to EN 10346

- Base plates from pre-galvanized steel S355 Fe Zn 12c according to EN 10025

3.7 General aspects related to the use of the product

The performance given in this ETA are based on the following:

- The structural members – the components 1 and 2 shown in the figure on page 13 – to which the brackets are fixed shall be:
 - Restrained against rotation.
 - Strength class C14 or better, see section 3 of this evaluation report
 - Free from wane under the bracket.
- The actual end bearing capacity of the timber member to be used in conjunction with the bracket is checked by the designer of the structure to ensure it is not less than the bracket capacity and, if necessary, the bracket capacity reduced accordingly.
- The gap between the timber members does not exceed 3 mm.
- There are no specific requirements relating to preparation of the timber members.

4 Assessment and verification of constancy of performance (AVCP)

4.1 AVCP system

According to the decision 97/638/EC of the European Commission¹, as amended, the system(s) of assessment and verification of constancy of performance (see Annex V to Regulation (EU) No 305/2011) is 2+.

5 Technical details necessary for the implementation of the AVCP system, as foreseen in the applicable EAD

Technical details necessary for the implementation of the AVCP system are laid down in the control plan deposited at ETA-Danmark prior to CE marking.

Issued in Copenhagen on 2022-08-25 by

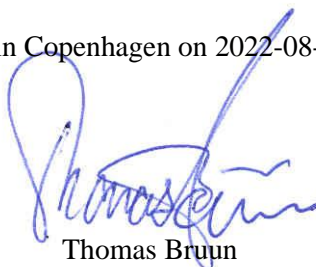

Thomas Bruun
Managing Director, ETA-Danmark

Annex A
Product details definitions

Table A.1 Materials specification

Nailing plate type	Thickness (mm)	Steel specification	Coating specification
Hold-down 340 or 440	3,0	S355	FeZn12c
Hold-down HighLoad	3,0	S355	FeZn12c
Shear angle 230x120	3,0	S250GD	Z 275
Shear angle H-H or H-B	2,5	S235	FeZn12c
CLT Systemwinkel	4,0	S250GD	Z 275
3D CLT Systemecke	4,0	S250GD	Z 275
Shear plate 240x230	3,0	S250GD	Z 275
Tension strap HH60	3,0	S250GD	Z 275
Tension strap HH70	3,0	S250GD	Z 275
Tension strap HB60	3,0	S250GD	Z 275
Tension strap HB70	3,0	S250GD	Z 275
Base plate 60	10,0	S235	FeZn12c
Base plate 230	12,0	S235	FeZn12c
Base plate HL	40,0	S235	FeZn12c
Lifting anchor 40x80	40	S235JR	-
Lifting anchor 40x49	40	S235JR	-

Table A.2 Range of sizes

Angle Bracket type	Height (mm) vertical		Height (mm) horizontal		Width (mm)	
Hold-down 340 or 440	339	341	62	64	59	61
Shear angle 230x120	119	121	119	121	229	231
Hold-down HighLoad	749	751	84	86	139	141
Shear angle H-H	69	71	69	71	229	231
Shear angle H-B	95	97	69	71	229	231
CLT Systemwinkel	119	121	79	81	229	231
3D CLT Systemecke	119	121	119	121	119	121
Shear plate 240x230	7,5	8,5	239	241	229	231
Tension strap HH60	7,5	8,5	679	681	59	61
Tension strap HH70	7,5	8,5	739	741	69	71
Tension strap HB60	7,5	8,5	505	507	59	61
Tension strap HB70	7,5	8,5	505	507	69	71
Base plate 60	9,5	10,5	49	51	57	59
Base plate 230	11,5	12,5	67	69	229	231
Base plate HL	39,0	41,0	81	83	129	131
Lifting anchor 40x80	79,5	80,5	-	-	39,5	40,5
Lifting anchor 40x49	48,5	49,5	-	-	39,5	40,5

Table A.3 Fastener specification

Fastener	Length	Profiled Length	Fastener type
EuroTec connector nail 4.0 mm	40 mm	25 mm	Ringed shank nails according to ETA-22/0083
	50 mm	35 mm	
	60 mm	45 mm	
E.u.r.o. Tec WBS screw 5.0 mm	25 mm	16 mm	Self-tapping screws according to ETA-11/0024
	40 mm	31 mm	
	50 mm	41 mm	
	60 mm	51 mm	
	70 mm	61 mm	
E.u.r.o. Tec Paneltwistec screw 5.0 mm	120 mm	70 mm	
E.u.r.o. Tec VSS screw 6.0 mm	60 mm	53 mm	
E.u.r.o. Tec KonstruX screw 10.0 mm	125 mm	116 mm	

In the load-carrying-capacities of the nailed or screwed connection in Annex B the capacities calculated from the formulas of Eurocode 5 are used assuming a thick steel plate when calculating the lateral fastener load-carrying-capacity. The characteristic withdrawal capacity of the nails or screws is determined by calculation in accordance with EN 1995-1-1:2010, paragraph 8.3.2 (head pull-through is not relevant):

$$F_{ax,Rk} = f_{ax,k} \cdot d \cdot t_{pen} \quad \text{for the EuroTec connector nails 4.0 mm}$$

$$F_{ax,Rk} = k_{ax} \cdot f_{ax,k} \cdot d \cdot \ell_{ef} \left(\frac{\rho_k}{\rho_a} \right)^{0,8} \quad \text{for the screws 5.0 mm}$$

where:

- k_{ax} Factor taking into account the angle between screw axis and grain direction; $k_{ax} = 1$ for $\alpha \leq 45^\circ$
- $f_{ax,k}$ Characteristic value of the withdrawal parameter in N/mm^2
- d Nail or screw diameter in mm
- t_{pen} Penetration depth of the profiled shank in mm
- ρ_k Characteristic density of the timber in kg/m^3
- ρ_a Characteristic density of the timber in kg/m^3 according to $f_{ax,k}$

Based on ETA-22/0083 the characteristic value of the withdrawal resistance and the characteristic value of fastener's yield moment for EuroTec connector nails $d = 4.0$ mm is:

$$f_{ax,k}^{ax,k} = 4,84 \text{ N/mm}^2 \text{ for nails } 4 \times 40, f_{ax,k} = 5,09 \text{ N/mm}^2 \text{ for nails } 4 \times 50, f_{ax,k} = 5,23 \text{ N/mm}^2 \text{ for nails } 4 \times 60$$

$$M_{y,k} = 6480 \text{ Nmm}$$

Based on ETA-11/0024 the characteristic value of the withdrawal resistance and the characteristic value of fastener's yield moment for E.u.r.o. Tec screws $d = 5.0$ mm is:

$$f_{ax,k} = 12,1 \text{ N/mm}^2$$

$$M_{y,k} = 5910 \text{ Nmm}$$

The shape of the nail or screw directly under the head shall be in the form of a truncated cone with a diameter under the head which fits or exceeds the hole diameter.

Bolt diameter	Correspondent hole diameter	Bolts type
12.0 to 28.0 mm	Max. 2 mm larger than the bolt diameter	See specification of the manufacturer

Metal Anchor diameter	Correspondent Hole diameter	Anchors type
12.0 to 28.0 mm	Max. 2 mm larger than the anchor diameter	See specification of the manufacturer

Annex B
Characteristic load-carrying capacities

Table 1: $F_{t,Rk}$ per nailing plate with washer or base plate / connection timber to timber or timber to concrete or steel

Type	Timber $\rho_k = 350 \text{ kg/m}^3$						steel	bolt	concrete
	capacity per fastener in the vertical flange $F_{v,Rk}$ [kN]						$F_{t,Rk}$ [kN]	$k_{t,II}$	ℓ_D [mm]
	Nails			Screws					
	4x40	4x50	4x60	5x40	5x50	5x60			
Hold-down 340 or 440 + washer 30x3 or base plate	1,90	2,26	2,45	2,14	2,28	2,43	57,1	1,4	10
Hold-down HighLoad + base plate HL	1,90	2,26	2,45	2,14	2,28	2,43	See equation (B.1)	1,4	10
Shear angle 230x120 + base plate 230	1,90	2,26	2,45	2,14	2,28	2,43	116	1,7	10
	capacity per shear angle $F_{1,Rk}$ [kN]						$F_{t,Rk}$ [kN]	$k_{t,II}$	ℓ_D [mm]
Shear angle H-B* + base plate 230 + 2 bolts M12 close to bend line	30,0						120	2,0	10
* 6 screws 5x120 and 3 screws 5x25 per flap									

Characteristic load-carrying capacity $F_{t,Rk}$ for Hold-down HighLoad:

$$F_{t,Rk} = \min \left\{ A \cdot f_{y,k}; 0,9 \cdot A_{net} \cdot f_{u,k} \right\} \quad (\text{B.1})$$

Where:

- A Cross-section area of the vertical flap in mm^2
 $A = 210 \cdot (1+h_f/600)$ in mm^2
- h_f Distance of the lowermost nail or screw from the upper end of the vertical flap in mm
- $f_{y,k}$ Characteristic yield strength of vertical flap in N/mm^2 , $f_{y,k} = 355 \text{ MPa}$
- $f_{u,k}$ Characteristic ultimate strength of vertical flap in N/mm^2 , $f_{u,k} = 510 \text{ MPa}$
- A_{net} Net cross-section area of the vertical flap in mm^2
 $A_{net} = 210 \cdot (1+h_f/600) - n_h \cdot 15$ in mm^2
- n_h Number of nail or screw holes in the cross-section at the lowermost fastener

Table 2: $F_{t,Rk}$ per nailing plate / timber to timber connection

Type	Timber $\rho_k = 350 \text{ kg/m}^3$	steel
	capacity per inclined screw 5x120 $F_{v,Rk}$ [kN]	$F_{t,Rk}$ [kN]
Tension strap HH60 or HB60	3,74	28,5
Tension strap HH70 or HB70	3,74	37,4
Shear angle H-H*	capacity per shear angle $F_{1,Rk}$ [kN]	120
	30,0	
* 6 screws 5x120 and 3 screws 5x25 per flap and 5 screws 10x125 per angle		

F_{1,Rk} per CLT Systemwinkel fastened with bolts or Ideefix connectors / CLT to CLT connection:

Without bolts or Ideefix connectors in the horizontal flap:

$$F_{1,Rk} = \min \left\{ \frac{1,25 \cdot n_s \cdot F_{ax,screw,Rk}}{\sqrt{2}}; n_v \cdot F_{v,IB,Rk} \right\} \quad (B.1)$$

With bolts or Ideefix connectors in the horizontal flap:

$$F_{1,Rk} = \min \left\{ \frac{n_s \cdot F_{ax,screw,Rk}}{\sqrt{2}} + 8 \text{ kN}; k_{IL} \cdot n_h \cdot F_{v,IB,Rk}; n_v \cdot F_{v,IB,Rk} \right\} \quad (B.2)$$

F_{1,Rk} per CLT Systemwinkel fastened with 5 mm screws in each 5 mm hole/ CLT to CLT connection:

Without 5 mm screws in the horizontal flap:

$$F_{1,Rk} = \frac{1,25 \cdot n_s \cdot F_{ax,screw,Rk}}{\sqrt{2}} \quad (B.3)$$

With 5 mm screws in the horizontal flap:

$$F_{1,Rk} = \min \left\{ \frac{n_s \cdot F_{ax,screw,Rk}}{\sqrt{2}} + 11 \cdot F_{ax,5mm,Rk} \right\} \quad (B.4)$$

Where:

n_s	Number of KonstruX screws arranged under 45°, $2 \leq n_s \leq 4$
n_h	Number of bolts or Ideefix connectors in the horizontal flap, $2 \leq n_h \leq 3$
n_v	Number of bolts or Ideefix connectors in the vertical flap, $2 \leq n_v \leq 3$
$F_{ax,screw,Rk}$	Characteristic axial capacity of a 45° KonstruX screw according to ETA-11/0024,
$F_{ax,5mm,Rk}$	Characteristic axial capacity of a 5 mm screw according to ETA-11/0024,
$F_{v,IB,Rk}$	Characteristic lateral load-carrying capacity of a bolt ($F_{v,IB,Rk} = F_{v,bolt,Rk}$) for thick steel plates according to EN 1995-1-1 or an Ideefix connector ($F_{v,IB,Rk} = F_{v,Ideefix,Rk}$),
$F_{v,Ideefix,Rk}$	= 20,8 kN for CLT member ($\rho_k = 400 \text{ kg/m}^3$) and $\alpha = 0^\circ$,
$F_{v,Ideefix,Rk}$	= 16,9 kN for CLT member ($\rho_k = 400 \text{ kg/m}^3$) and $\alpha = 90^\circ$,
α	Angle between load and grain direction of the outer CLT layer, linear interpolation should be applied for $0^\circ < \alpha < 90^\circ$,
k_{IL}	Modification factor for the fastener's capacity reduction due to a 6 mm interlayer,
k_{IL}	= 0,9 for bolts or Ideefix connectors.

F_{1,Rk} per 3D CLT Systemecke / CLT to CLT wall-wall-floor connection, $\rho_k = 400 \text{ kg/m}^3$:

$$F_{1,Rk} = 30 \text{ kN for fastener configuration 1} \quad (B.5)$$

$$F_{1,Rk} = 40 \text{ kN for fastener configuration 2} \quad (B.6)$$

$$F_{1,Rk} = 50 \text{ kN for fastener configuration 3} \quad (B.7)$$

$$F_{1,Rk} = 60 \text{ kN for fastener configuration 4} \quad (B.8)$$

Where:

Fastener configuration 1: Two 40 mm Ideefix connectors with 8 VSS screws 6x60 each or two 16 mm bolts 8.8 per vertical flap arranged in 17 mm holes, four KonstruX screws per horizontal flap arranged under 45 ° in 11 mm holes.

Fastener configuration 2: Two 40 mm Ideefix connectors with 8 VSS screws 6x60 each or two 16 mm bolts 8.8 per vertical flap arranged in 17 mm holes, two 40 mm Ideefix connectors with 8 VSS screws 6x60 each or two 16 mm bolts 8.8 per horizontal flap arranged in 17 mm holes, four KonstruX screws per horizontal flap arranged under 45 ° in 11 mm holes.

Fastener configuration 3: 17 WBS screws 5x50 per vertical flap arranged in 5 mm holes, 31 WBS screws 5x50 per horizontal flap arranged in 5 mm holes, four KonstruX screws per horizontal flap arranged under 45 ° in 11 mm holes.

Fastener configuration 4: Two 40 mm Ideefix connectors with 8 VSS screws 6x60 each or two 16 mm bolts 8.8 per vertical flap arranged in 17 mm holes, two 40 mm Ideefix connectors with 8 VSS

screws 6x60 each or two 16 mm bolts 8.8 per horizontal flap arranged in 17 mm holes, 13 WBS screws 5x50 per vertical flap arranged in 5 mm holes, 31 WBS screws 5x50 per horizontal flap arranged in 5 mm holes, four KonstruX screws per horizontal flap arranged under 45 ° in 11 mm holes.

Table 3: $F_{23,Rk}$ per nailing plate / timber-timber connection, $\rho_k = 350 \text{ kg/m}^3$

Type	Fastener pattern	Number of nails or screws per flap n_{na}	Number of inclined screws 5x120 per flap n_{sc}	F_{23Rk} [kN] with n_{na} nails			F_{23Rk} [kN] with n_{na} screws		
				4x40	4x50	4x60	5x40	5x50	5x60
Shear angle 230x120	Full	41	6	37,3	44,3	47,9	41,9	44,6	47,6
	Partial 1	34	6	29,1	34,6	37,4	32,7	34,9	37,2
	Partial 2	29	4	23,6	28,0	30,4	26,5	28,3	30,1
Shear angle 230x120 with 6 mm interlayer	Full	41	6	28,9	34,4	37,4	32,7	34,8	37,1
	Partial 1	34	6	22,6	26,9	29,4	25,5	27,2	29,0
	Partial 2	29	4	18,3	21,8	23,9	20,7	22,1	23,5
Shear plate 240x230	Full	41	6	37,3	44,3	47,9	41,9	44,6	47,6
	Partial 1	34	6	29,1	34,6	37,4	32,7	34,9	37,2
	Partial 2	29	4	23,6	28,0	30,4	26,5	28,3	30,1

$F_{23,Rk}$ per shear angle H-H with full screw pattern / timber-timber connection,
 $\rho_k = 350 \text{ kg/m}^3$ (6 screws 5x120 and 3 screws 5x25 per flap and 5 screws 10x125 per angle):

$F_{23,Rk} = 40 \text{ kN}$ without interlayer

$F_{23,Rk} = 36 \text{ kN}$ with interlayer under the horizontal flap

$F_{23,Rk}$ per shear angle H-B with full screw pattern* / timber-to-concrete or steel connection,
 $\rho_k = 350 \text{ kg/m}^3$ (6 screws 5x120 and 3 screws 5x25 per vertical flap):

$F_{23,Rk} = \min \{40 \text{ kN}; n_{ef} \cdot F_{v,bolt,Rk}\}$

Where $n_{ef} = 1,89$ for two bolts close to bend line, $n_{ef} = 1,48$ for two bolts away from bend line

$F_{ax,Rk}$ per lifting anchor 40x80 or 40x49 parallel to anchor axis with full screw pattern,
(8 VSS screws 6x60):

$$F_{ax,Rk} = 0,218 \cdot \rho_k^{0,8} \text{ kN}$$

for CLT members and glulam members loaded perpendicular to member plane or parallel to grain,

$$F_{ax,Rk} = \min \left\{ 0,218 \cdot \rho_k^{0,8}; \frac{0,5 \cdot h}{h - 60} \left(0,0065 + \frac{64,8}{h^2} \right) \cdot (100 \cdot h)^{0,8} \right\} \text{ kN}$$

for glulam members loaded in plane perpendicular to grain,

$F_{v,Rk}$ per lifting anchor 40x80 perpendicular to anchor axis with full screw pattern,
load eccentricity $e = 38 \text{ mm}$ to member surface, (8 VSS screws 6x60):

$$F_{v,Rk} = \frac{0,057 \cdot \rho_k}{\max \{1,95 \cdot \sin^2 \alpha + \cos^2 \alpha; 2,5 \cdot \cos^2 \varepsilon + \sin^2 \varepsilon\}} \text{ kN}$$

$F_{v,Rk}$ per lifting anchor 40x49 perpendicular to anchor axis with full screw pattern,
load eccentricity $e = 25 \text{ mm}$ to member surface, (8 VSS screws 6x60):

$$F_{v,Rk} = \frac{0,032 \cdot \rho_k}{\max \{1,95 \cdot \sin^2 \alpha + \cos^2 \alpha; 2,5 \cdot \cos^2 \varepsilon + \sin^2 \varepsilon\}} \text{ kN}$$

Where

α Angle between load and grain direction;

for anchors in wide surface of CLT: $\alpha =$ angle between load and grain direction of outer

- layer,
 for anchors in edge or end grain surface of CLT loaded in plane: $\alpha = 0^\circ$,
 for anchors in edge or end grain surface of CLT loaded perpendicular to member plane: $\alpha = 90^\circ$,
 ε Angle between anchor axis and grain direction;
 for anchors in CLT: $\varepsilon = 90^\circ$,
 h Glulam member depth in mm.

$F_{23,Rk}$ per CLT Systemwinkel / CLT to CLT connection:

With bolts or Ideefix connectors only in the vertical flap:

$$F_{23,Rk} = \min \left\{ k_{IL} \cdot n_s \cdot F_{v,screw,Rk} ; \frac{F_{v,IB,Rk}}{\sqrt{\frac{1}{n_v^2} + 0,28}} \right\} \quad (B.9)$$

With bolts or Ideefix connectors in the vertical and horizontal flap:

$$F_{23,Rk} = \min \left\{ k_{IL} \cdot n_s \cdot F_{v,screw,Rk} + \frac{k_{IL} \cdot F_{v,IB,Rk}}{\sqrt{\frac{1}{n_h^2} + 0,1}} ; \frac{F_{v,IB,Rk}}{\sqrt{\frac{1}{n_v^2} + 0,28}} \right\} \quad (B.10)$$

With 43 Paneltwistec or WBS screws each in the vertical and horizontal flap:

$$F_{23,Rk} = 71,8 \text{ kN for } 5 \times 120 \text{ mm Paneltwistec screws without interlayer} \quad (B.11)$$

$$F_{23,Rk} = 63,6 \text{ kN for } 5 \times 120 \text{ mm Paneltwistec screws with 6 mm interlayer under horizontal flap} \quad (B.12)$$

$$F_{23,Rk} = 68,1 \text{ kN for } 5 \times 70 \text{ mm WBS screws without interlayer} \quad (B.13)$$

$$F_{23,Rk} = 58,4 \text{ kN for } 5 \times 70 \text{ mm WBS screws with 6 mm interlayer under horizontal flap} \quad (B.14)$$

Where:

- n_s Number of KonstruX screws arranged under 45° , $2 \leq n_s \leq 4$
 n_h Number of bolts or Ideefix connectors in the horizontal flap, $2 \leq n_h \leq 3$
 n_v Number of bolts or Ideefix connectors in the vertical flap, $2 \leq n_v \leq 3$
 $F_{v,screw,Rk}$ Characteristic lateral capacity of a 45° KonstruX screw according to ETA-11/0024,
 For CLT ($\rho_k = 400 \text{ kg/m}^3$): $F_{v,screw,Rk} = 5,28 \text{ kN}$,
 $F_{v,IB,Rk}$ Characteristic lateral load-carrying capacity of a bolt ($F_{v,IB,Rk} = F_{v,bolt,Rk}$) for thick steel plates according to EN 1995-1-1 or an Ideefix connector ($F_{v,IB,Rk} = F_{v,Ideefix,Rk}$),
 $F_{v,Ideefix,Rk}$ = 20,8 kN for CLT member ($\rho_k = 400 \text{ kg/m}^3$) and $\alpha = 0^\circ$,
 $F_{v,Ideefix,Rk}$ = 16,9 kN for CLT member ($\rho_k = 400 \text{ kg/m}^3$) and $\alpha = 90^\circ$,
 α Angle between load and grain direction of the outer CLT layer, linear interpolation should be applied for $0^\circ < \alpha < 90^\circ$,
 k_{IL} Modification factor for the fastener's capacity reduction due to a 6 mm interlayer,
 k_{IL} = 0,9 for bolts or Ideefix connectors.

$F_{2/3/4,Rk}$ per 3D CLT Systemecke / CLT to CLT wall-wall-floor connection, $\rho_k = 400 \text{ kg/m}^3$:

$$F_{2/3/4,Rk} = 15 \text{ kN for fastener configuration 1} \quad (B.15)$$

$$F_{2/3/4,Rk} = 52 \text{ kN for fastener configuration 2} \quad (B.16)$$

$$F_{2/3/4,Rk} = 65 \text{ kN for fastener configuration 3} \quad (B.17)$$

$$F_{2/3/4,Rk} = 70 \text{ kN for fastener configuration 4} \quad (B.18)$$

$F_{2/3/5,Rk}$ per 3D CLT Systemecke / CLT to CLT wall-wall-floor connection, $\rho_k = 400 \text{ kg/m}^3$:

$$F_{2/3/5,Rk} = 10 \text{ kN for fastener configuration 1} \quad (\text{B.19})$$

$$F_{2/3/5,Rk} = 28 \text{ kN for fastener configuration 2} \quad (\text{B.20})$$

$$F_{2/3/5,Rk} = 44 \text{ kN for fastener configuration 3} \quad (\text{B.21})$$

$$F_{2/3/5,Rk} = 50 \text{ kN for fastener configuration 4} \quad (\text{B.22})$$

Fastener configurations are defined below equation (B.8).

$F_{4,Rk}$ per shear angle H-H with full screw pattern / timber-timber connection, $\rho_k = 350 \text{ kg/m}^3$ (6 screws 5x120 and 3 screws 5x25 per flap and 5 screws 10x125 per angle):

$F_{4,Rk} = 40 \text{ kN}$ without interlayer

$F_{4,Rk} = 36 \text{ kN}$ with interlayer under the horizontal flap

$F_{4,Rk}$ per shear angle H-B with full screw pattern* / timber-to-concrete or steel connection, $\rho_k = 350 \text{ kg/m}^3$ (6 screws 5x120 and 3 screws 5x25 per vertical flap):

$F_{4,Rk} = \min \{40 \text{ kN}; n_B \cdot F_{v,bolt,Rk}\}$ with or without interlayer

Note: $F_{v,bolt,Rk}$ depends on the interlayer thickness

$F_{45,Rk}$ per CLT Systemwinkel / CLT to CLT connection with or without interlayer:

With 5 mm screws, bolts or Ideefix connectors only in the vertical flap:

$$F_{4,Rk} = \frac{n_s \cdot F_{ax,screw,Rk}}{\sqrt{2}} \quad (\text{B.23})$$

$$F_{5,Rk} = 0 \quad (\text{B.24})$$

With 5 mm screws, bolts or Ideefix connectors in the horizontal and vertical flap:

$$F_{4,Rk} = 54 \text{ kN} \quad (\text{B.25})$$

$$F_{5,Rk} = 4,8 \text{ kN for bolts or Ideefix connectors} \quad (\text{B.26})$$

$$F_{5,Rk} = 6,9 \text{ kN for Paneltwistec or WBS screws} \quad (\text{B.27})$$

$$F_{45,Rk} = F_{4,Rk} + F_{5,Rk} \quad (\text{B.28})$$

Where:

n_s Number of KonstruX screws arranged under 45° , $2 \leq n_s \leq 4$

$F_{ax,screw,Rk}$ Characteristic axial capacity of a 45° KonstruX screw according to ETA-11/0024.

Static ductility for shear angles 230x120 or CLT Systemwinkel in timber-to-timber connections with interlayer

When 4 mm ringed shank nails or 5 mm WBS or Paneltwistec screws are used to fix shear angles 230x120 or CLT Systemwinkel, the static ductility ratio for shear forces (load direction F_{23}) between CLT shear walls and timber floors exceeds 4. Consequently, ductility class DCM may be assumed in the design of these structures under earthquake loading.

Slip moduli

The slip modulus per shear angle H-H or H-B may be assumed as:

$$K_{1,ser} = 5 \text{ kN/mm}$$

$$K_{23,ser} = 15 \text{ kN/mm}$$

$$K_{4,ser} = 10 \text{ kN/mm}$$

The slip modulus per CLT Systemwinkel may be assumed as:

$$K_{1,ser} = \frac{F_{1,Rk}}{6 \text{ mm}}$$

$$K_{23,ser} = \frac{F_{23,Rk}}{2 \text{ mm}}$$

$$K_{4,ser} = \frac{F_{4,Rk}}{2,5 \text{ mm}}$$

$$K_{5,ser} = \frac{F_{5,Rk}}{2,5 \text{ mm}}$$

The slip modulus per 3D CLT Systemecke may be assumed as:

Fastener configuration 1: $K_{1,ser} = 6 \text{ kN/mm}$ $K_{234,ser} = 2,5 \text{ kN/mm}$ $K_{235,ser} = 5 \text{ kN/mm}$

Fastener configuration 2: $K_{1,ser} = 10 \text{ kN/mm}$ $K_{234,ser} = 10 \text{ kN/mm}$ $K_{235,ser} = 2,5 \text{ kN/mm}$

Fastener configuration 3: $K_{1,ser} = 20 \text{ kN/mm}$ $K_{234,ser} = 18 \text{ kN/mm}$ $K_{235,ser} = 10 \text{ kN/mm}$

Fastener configuration 4: $K_{1,ser} = 20 \text{ kN/mm}$ $K_{234,ser} = 18 \text{ kN/mm}$ $K_{235,ser} = 10 \text{ kN/mm}$

Combined forces in CLT Systemwinkel

If the forces F_1 , $F_{2/3}$ or F_4/F_5 act at the same time, the following inequality shall be fulfilled:

$$\left(\frac{F_{1,Ed}}{F_{1,Rd}}\right)^2 + \left(\frac{F_{23,Ed}}{F_{23,Rd}}\right)^2 + \left(\frac{F_{4,Ed}}{F_{4,Rd}}\right)^2 + \left(\frac{F_{5,Ed}}{F_{5,Rd}}\right)^2 \leq 1$$

The forces F_4 and F_5 are forces with opposite direction. Therefore, only one force F_4 or F_5 is able to act simultaneously with F_1 or F_{23} , while the other shall be set to zero.

Combined forces in 3D CLT Systemecke

If the forces F_1 , $F_{2/3/4}$ or $F_{2/3/5}$ act at the same time, the following inequality shall be fulfilled:

$$\left(\frac{F_{1,Ed}}{F_{1,Rd}}\right)^2 + \left(\frac{F_{234,Ed}}{F_{234,Rd}}\right)^2 + \left(\frac{F_{235,Ed}}{F_{235,Rd}}\right)^2 \leq 1$$

The forces F_{234} and F_{235} are forces with opposite direction. Therefore, only one force F_{234} or F_{235} is able to act simultaneously with F_1 , while the other shall be set to zero.

Definitions of forces, their directions and eccentricity

Forces - Beam to beam connection

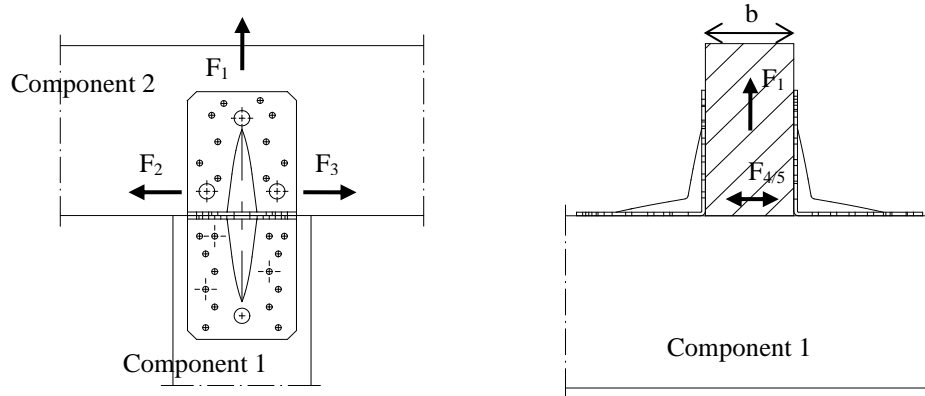

Forces – CLT wall to CLT wall to CLT floor connection

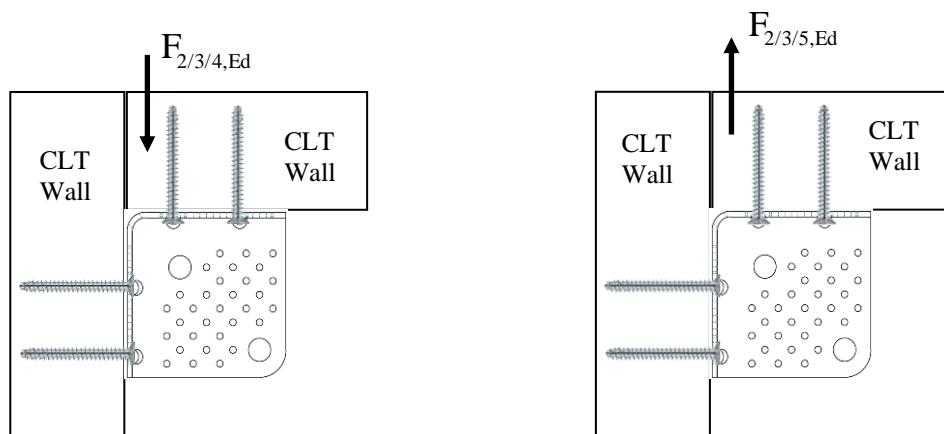

Fastener specification

Holes are marked referring to the fastener pattern.

Double angle brackets per connection

The angle brackets must be placed at each side opposite to each other, symmetrically to the component axis.

Acting forces

- F_1 Lifting force acting along the central axis of the joint.
- F_2 and F_3 Lateral force acting in the joint between the component 2 and component 1 in the component 2 direction
- $F_{4/5}$ Lateral force acting in the joint between the component 2 and component 1 in the component 1 direction

Single angle bracket per connection

Acting forces

- F_1 Lifting force acting in the central axis of the angle bracket. The component 2 shall be prevented from rotation.
- F_2 and F_3 Lateral force acting in the joint between the component 2 and the component 1 in the component 2 direction. The component 2 shall be prevented from rotation.
- F_4 Lateral force acting perpendicular to the central axis of the joint towards a shear angle.
- F_5 Lateral force acting perpendicular to the central axis of the joint away from a CLT Systemwinkel.

3D CLT Systemecke

Acting forces

- F_1 Lifting force perpendicular to the CLT floor. The walls shall be prevented from rotation.
- $F_{2/3/4}$ Lateral force acting parallel to one wall and perpendicular to the other wall towards a 3D Systemecke. The walls shall be prevented from rotation.
- $F_{2/3/5}$ Lateral force acting parallel to one wall and perpendicular to the other wall away from a 3D Systemecke. The walls shall be prevented from rotation.

Wane

Wane is not allowed; the timber has to be sharp-edged in the area of the angle brackets.

Timber splitting

For the lifting force F_1 it must be checked in accordance with Eurocode 5 or a similar national Timber Code that splitting will not occur.

Connection of timber to concrete or steel with bolts or metal anchors

The load $F_{B,Ed}$ for the design of the maximally loaded bolt or metal anchor is calculated as:

$$F_{B,t,Ed} = k_{t,II} \times F_{1,Ed}$$

$$\sigma_{C,Ed} = \frac{F_{1,Ed} \times (k_{t,II} - 1)}{b \times l_D}$$

where:

- $F_{B,t,Ed}$ Resulting tensile load on the maximally loaded bolt in the group in N
- $k_{t,II}$ Coefficient taking into account the resulting axial bolt force
- $F_{1,Ed}$ Tensile load F_1 on vertical flap of the angle bracket in N
- b Width of the washer in mm
- $\sigma_{C,Ed}$ compressive stress on the support in N/mm^2

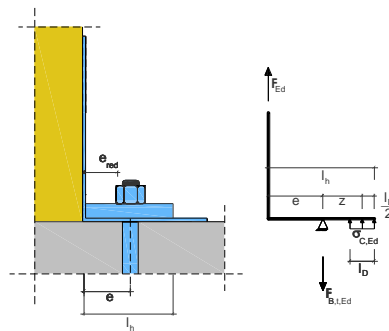

E.u.r.o. Tec Nailing Plates

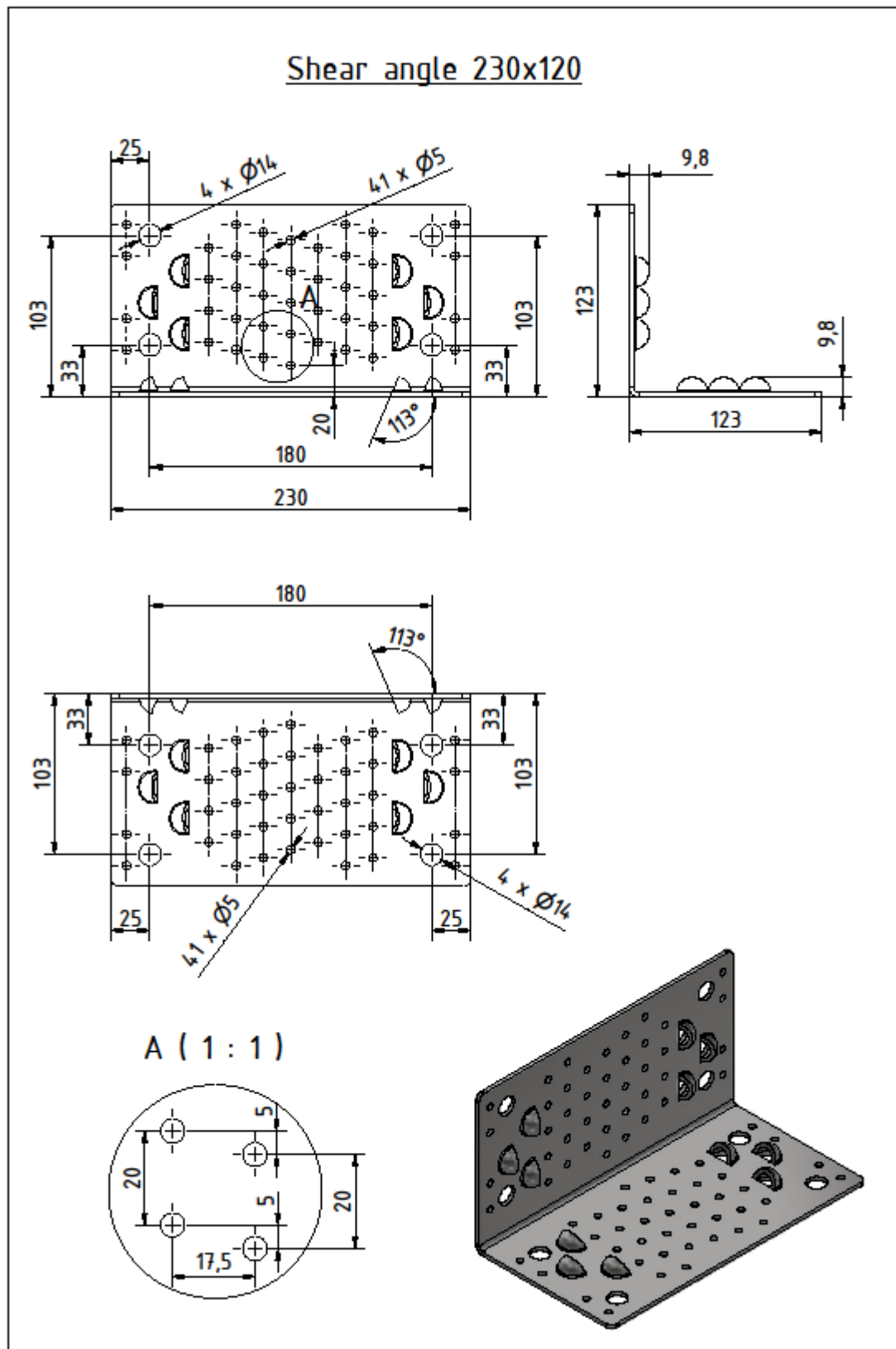

Figure B. 1 Dimensions of Shear Angle 230x120

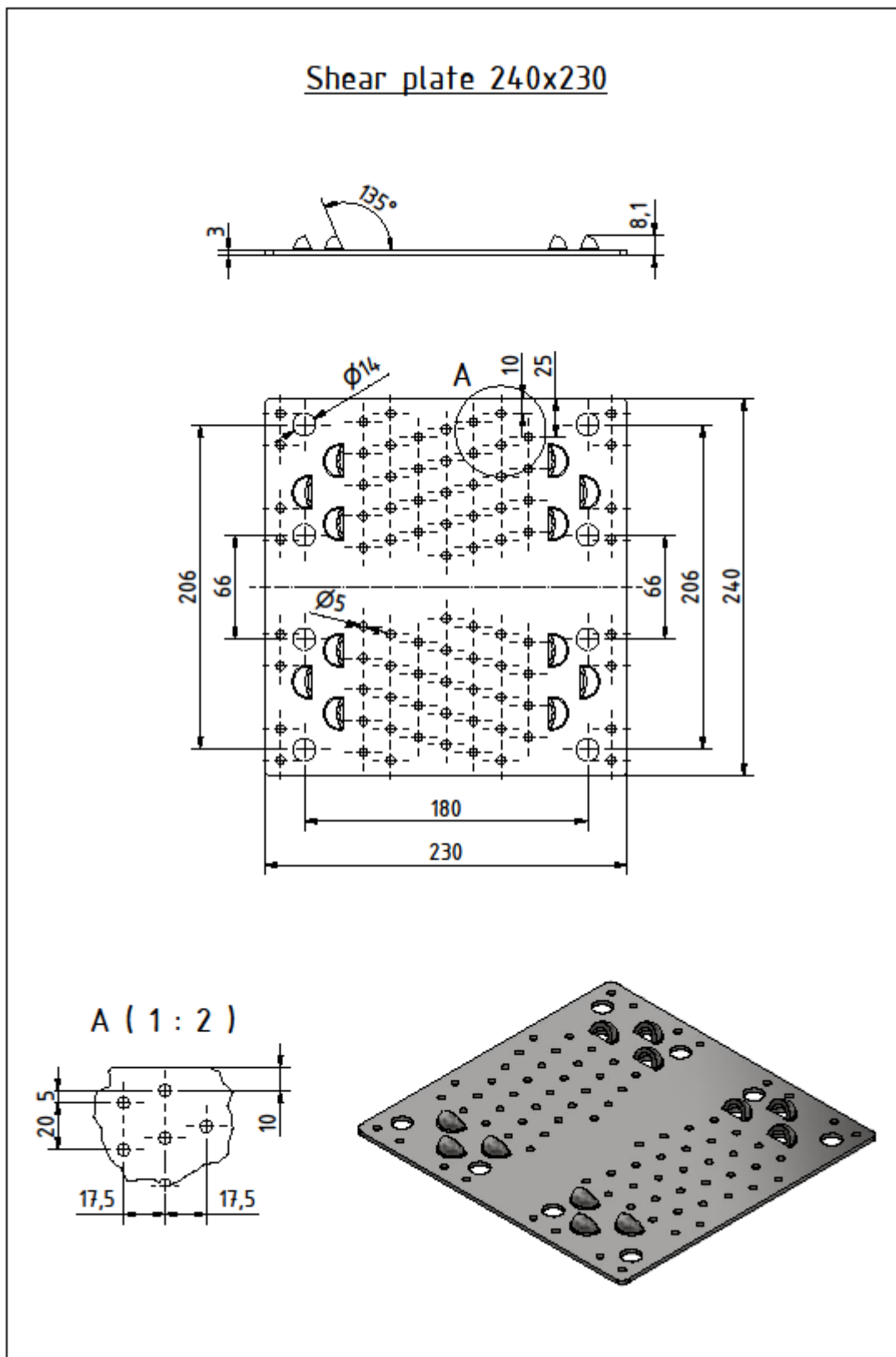

Figure B. 2 Dimensions of Shear Plate 240x230

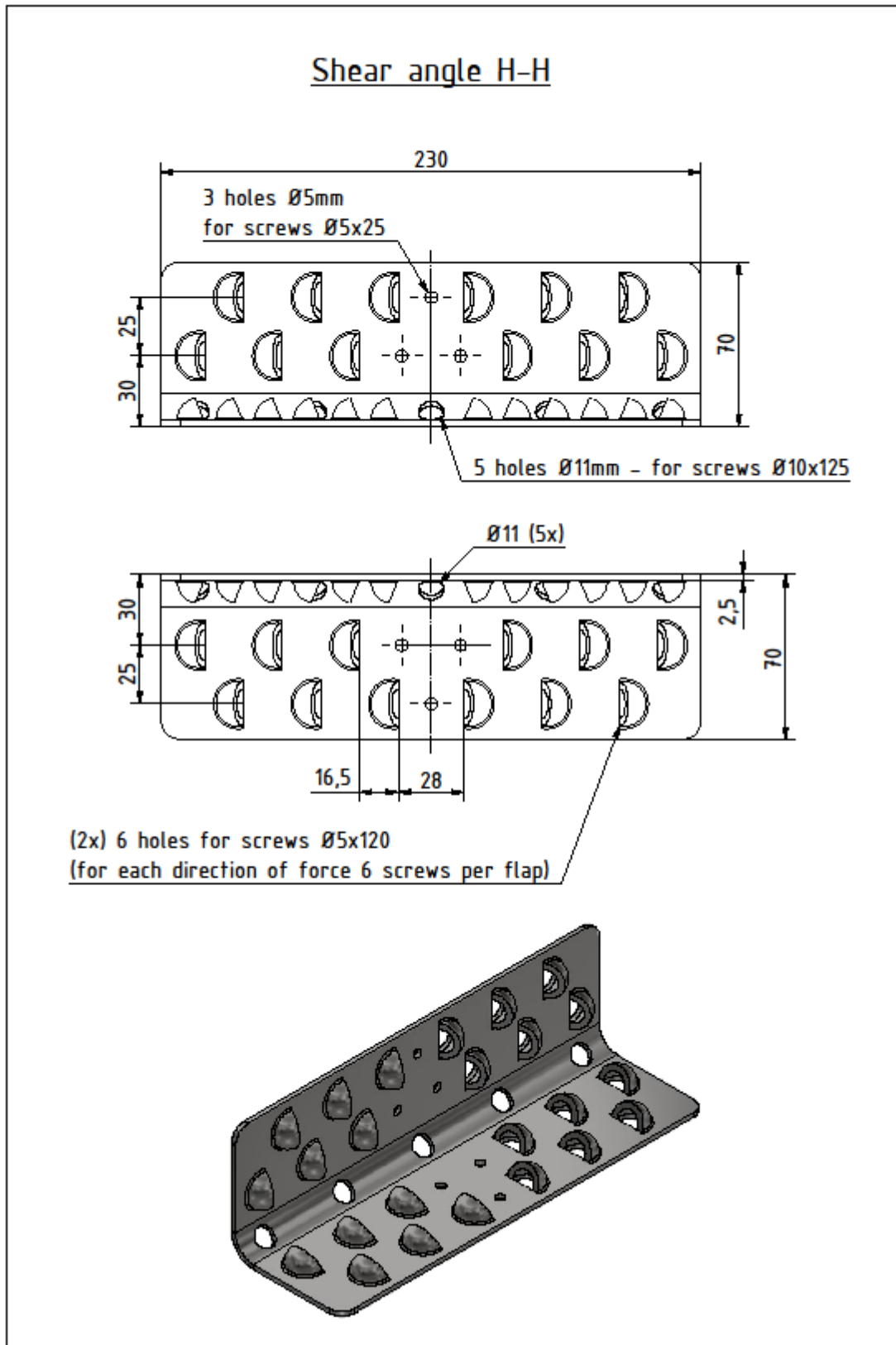

Figure B. 3 Dimensions of Shear Angle H-H

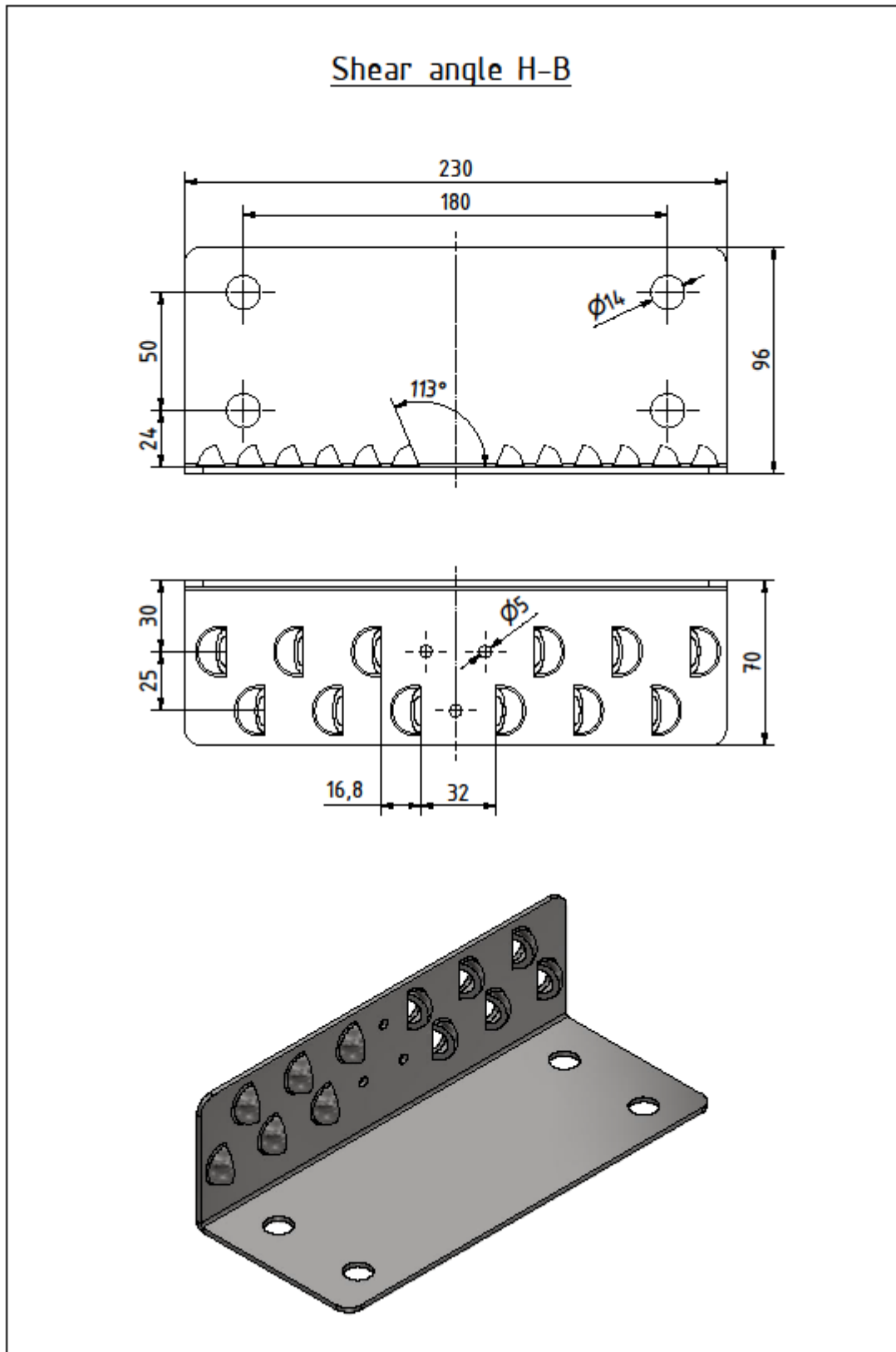

Figure B. 4 Dimensions of Shear Angle H-B

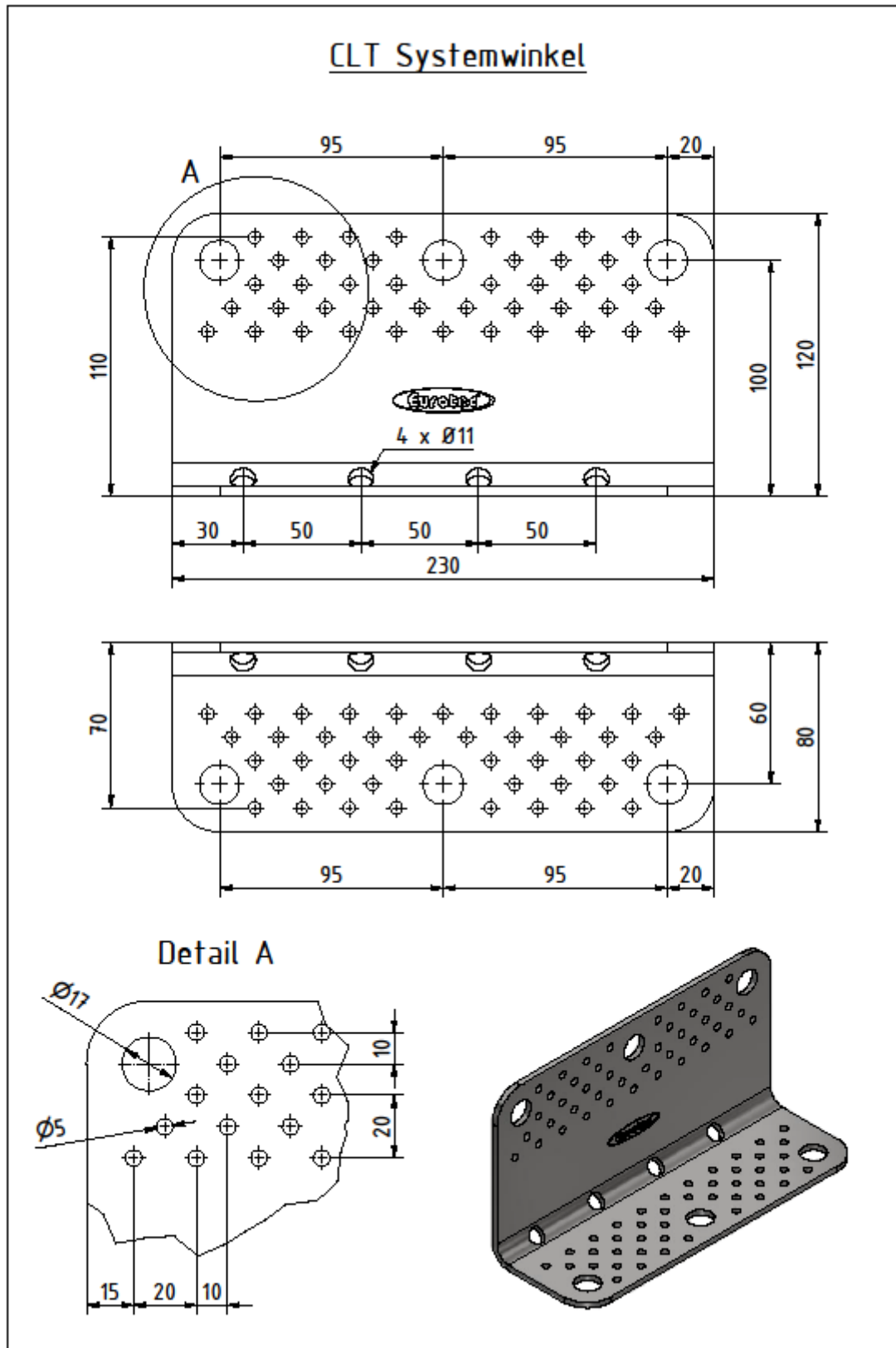

Figure B.5 Dimensions of CLT Systemwinkel

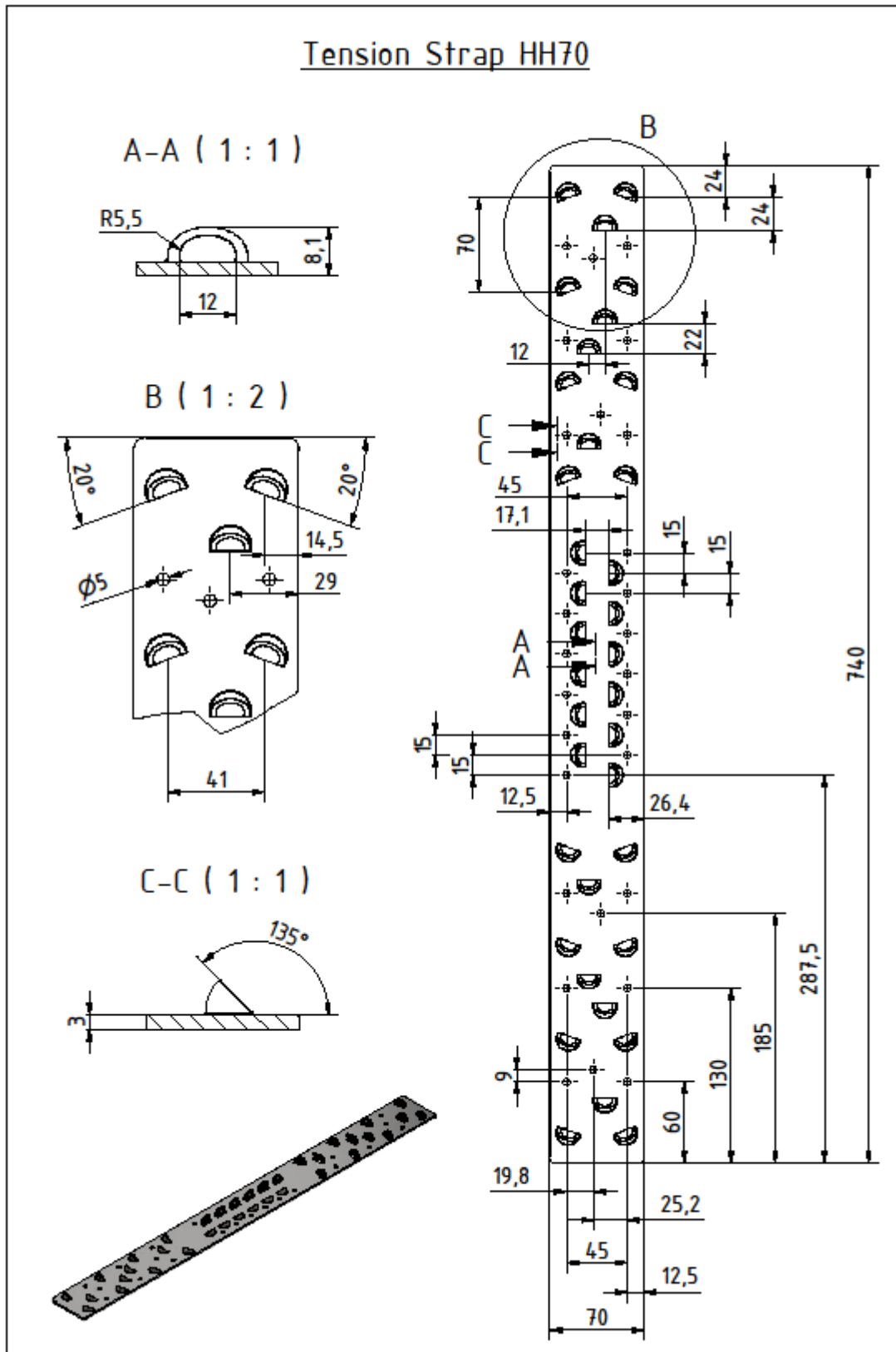

Figure B. 6 Dimensions of Tension Strap HH70

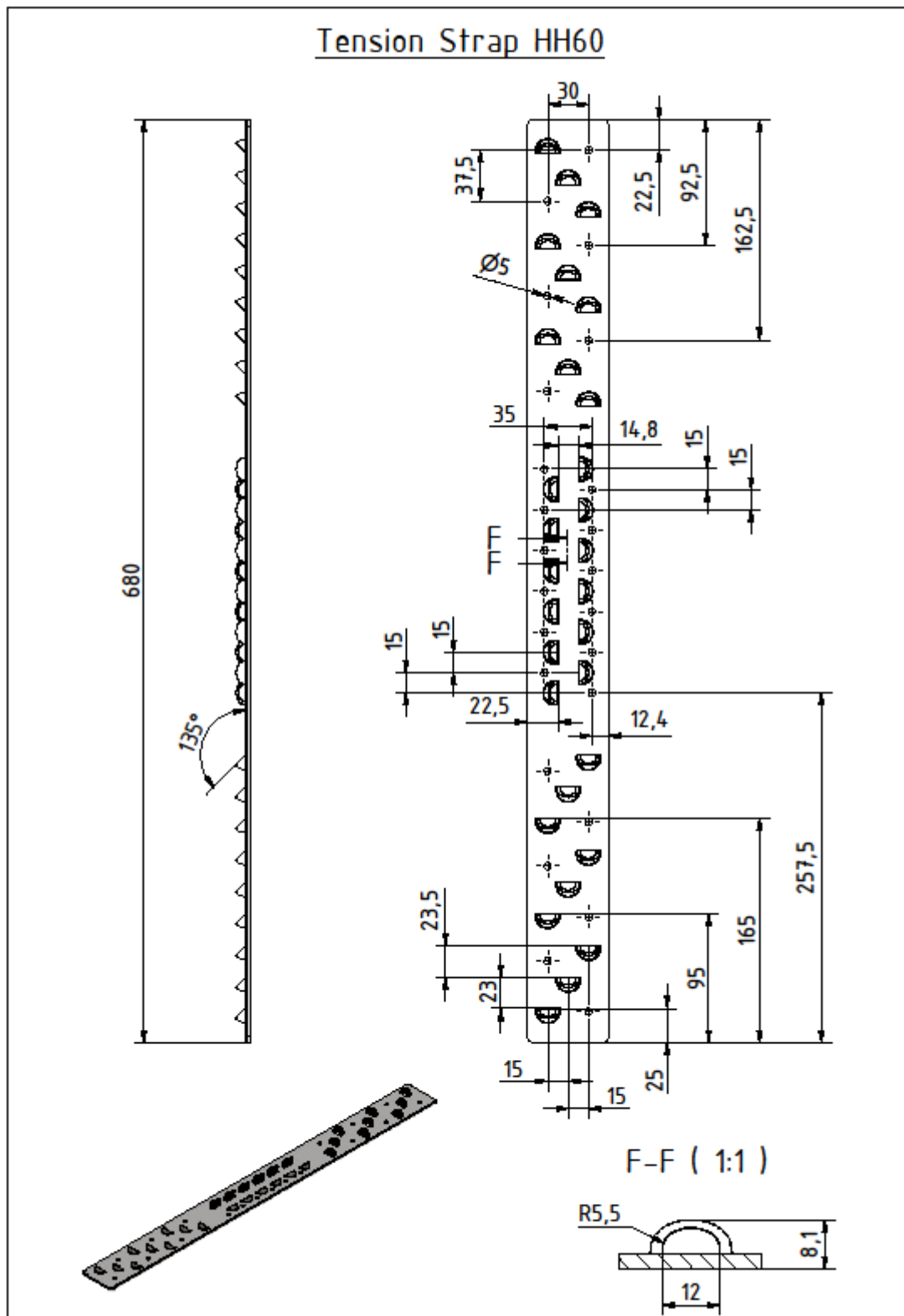

Figure B. 7 Dimensions of Tension Strap HH60

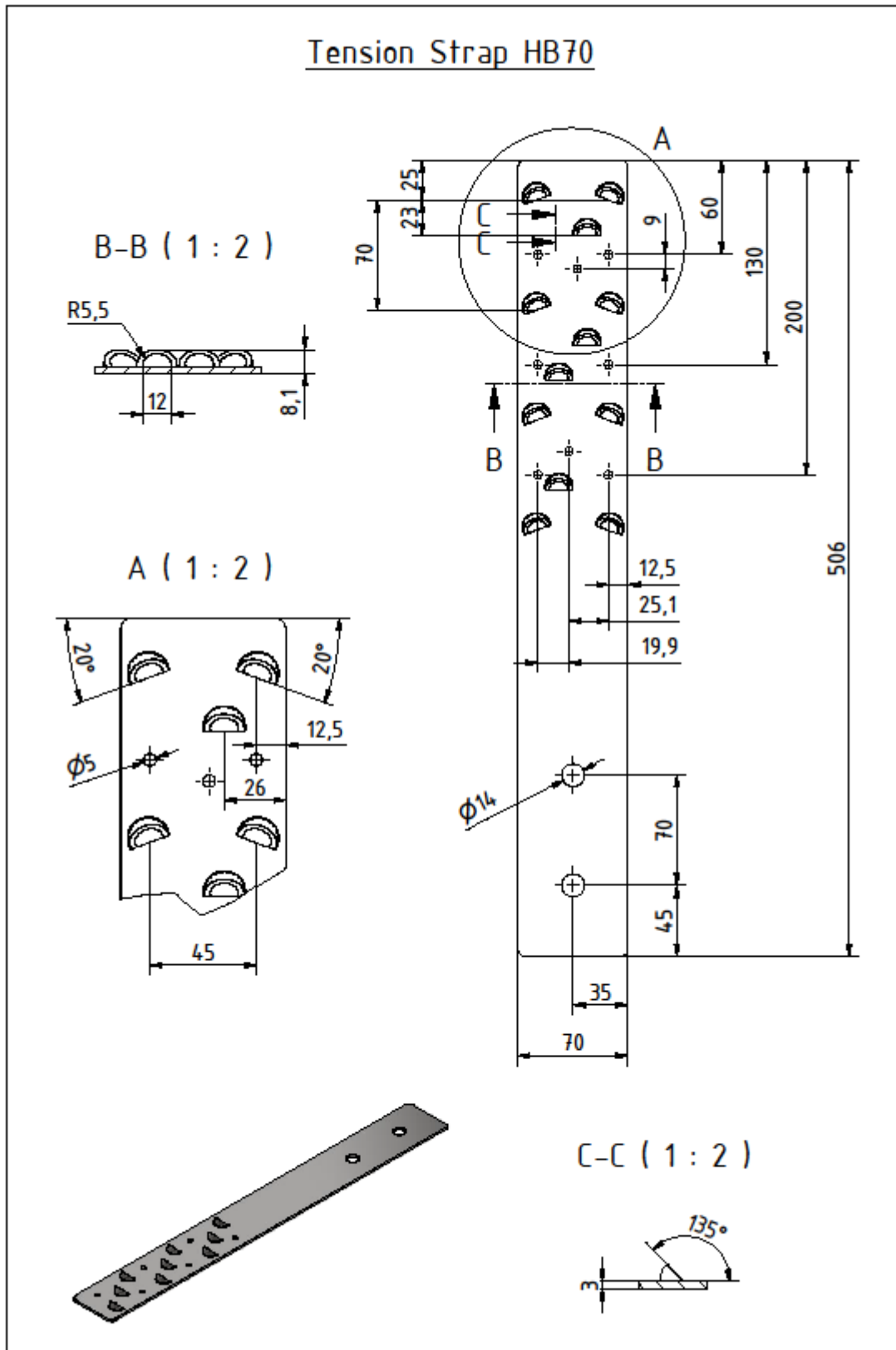

Figure B. 8 Dimensions of Tension Strap HB70

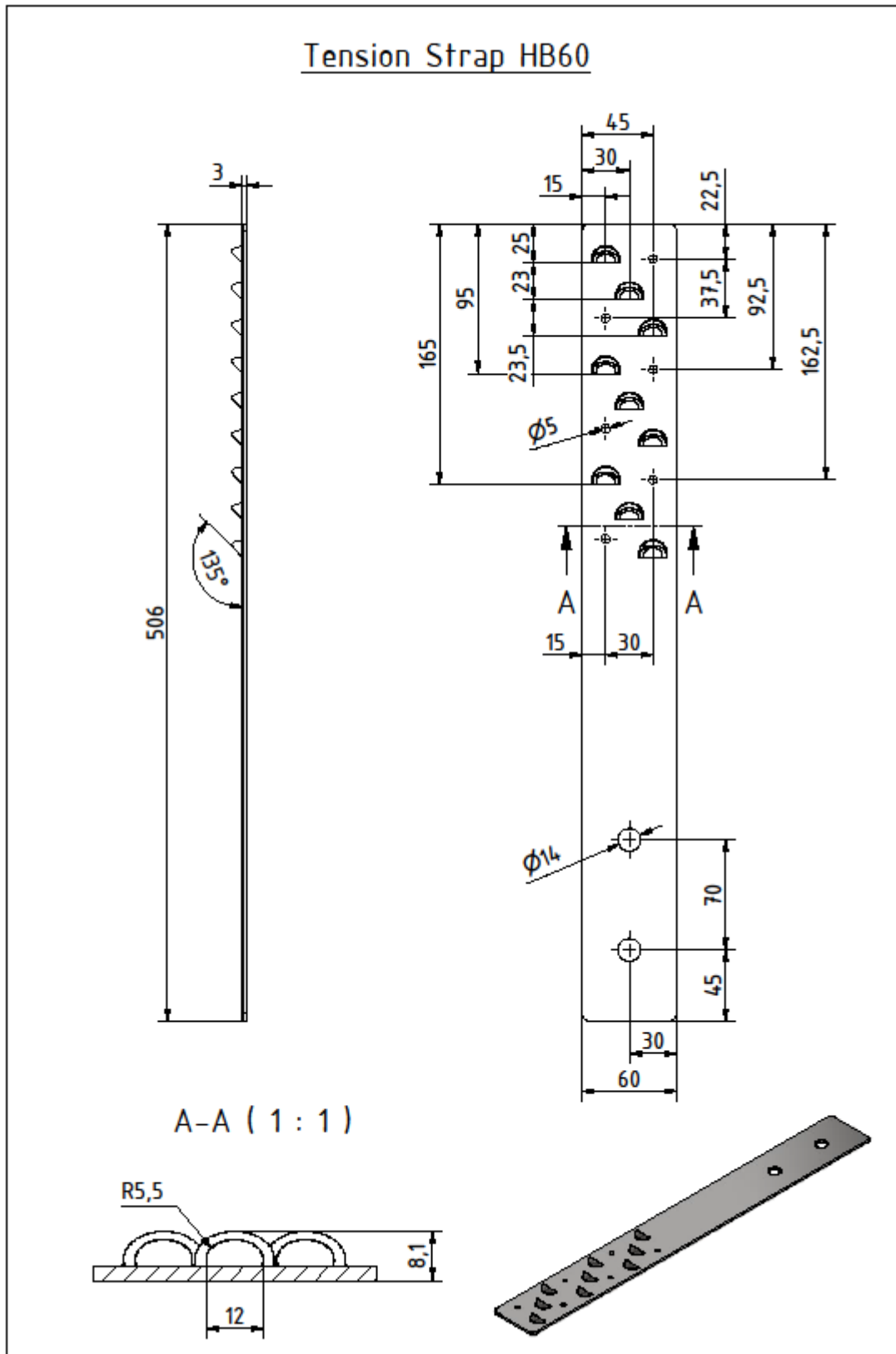

Figure B. 9 Dimensions of Tension Strap HB60

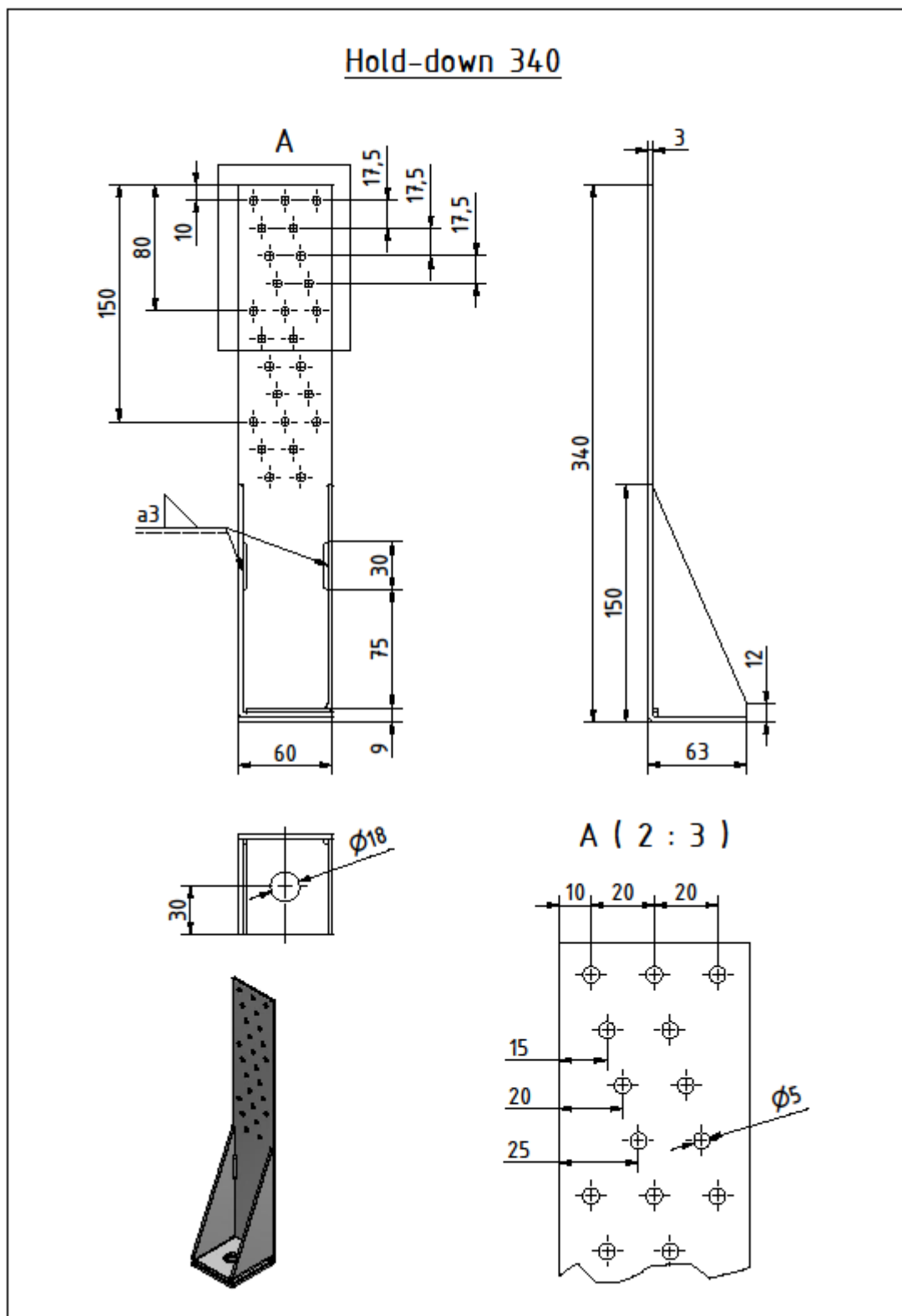

Figure B. 10 Dimensions of Hold-down 340

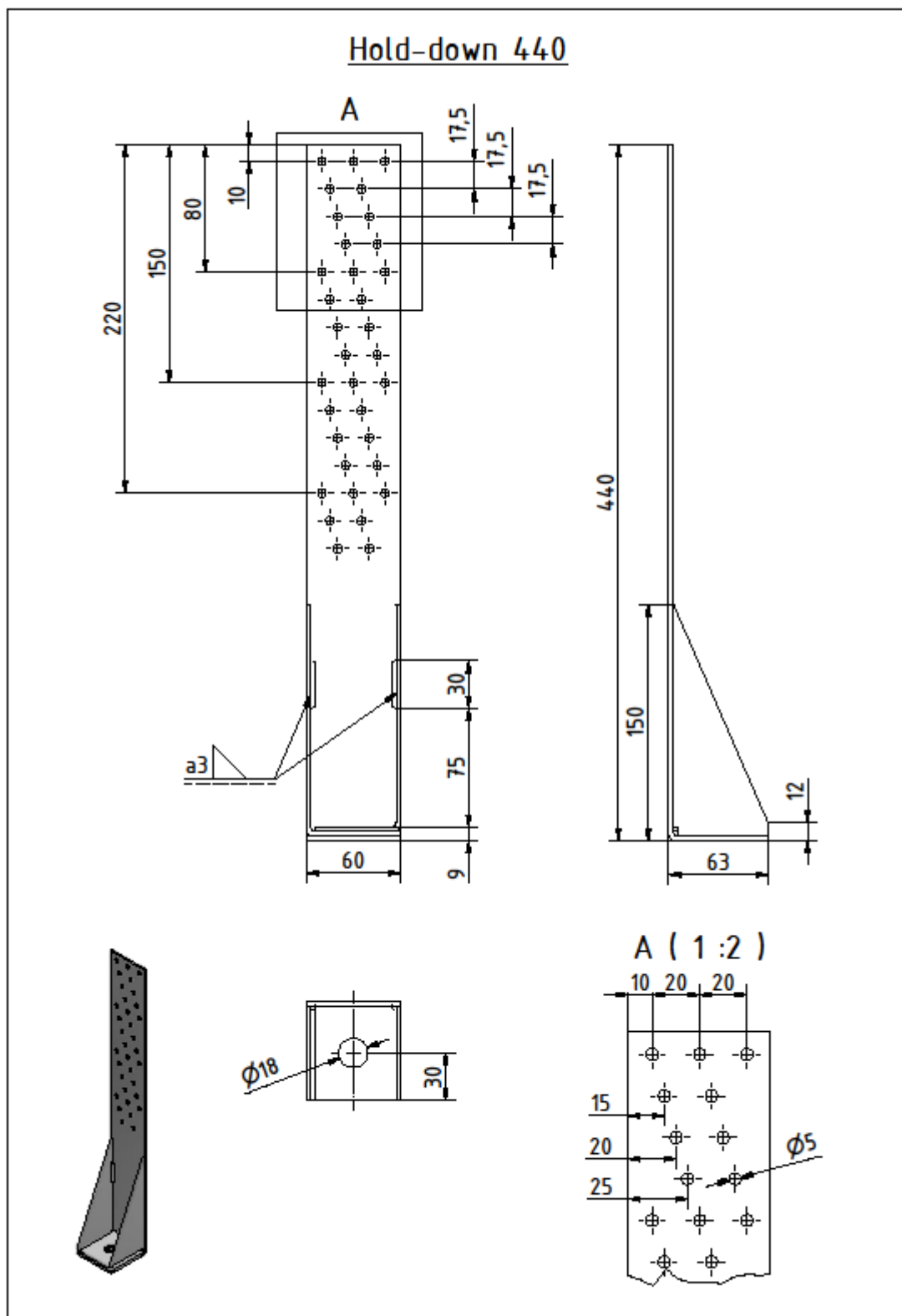

Figure B. 11 Dimensions of Hold-down 440

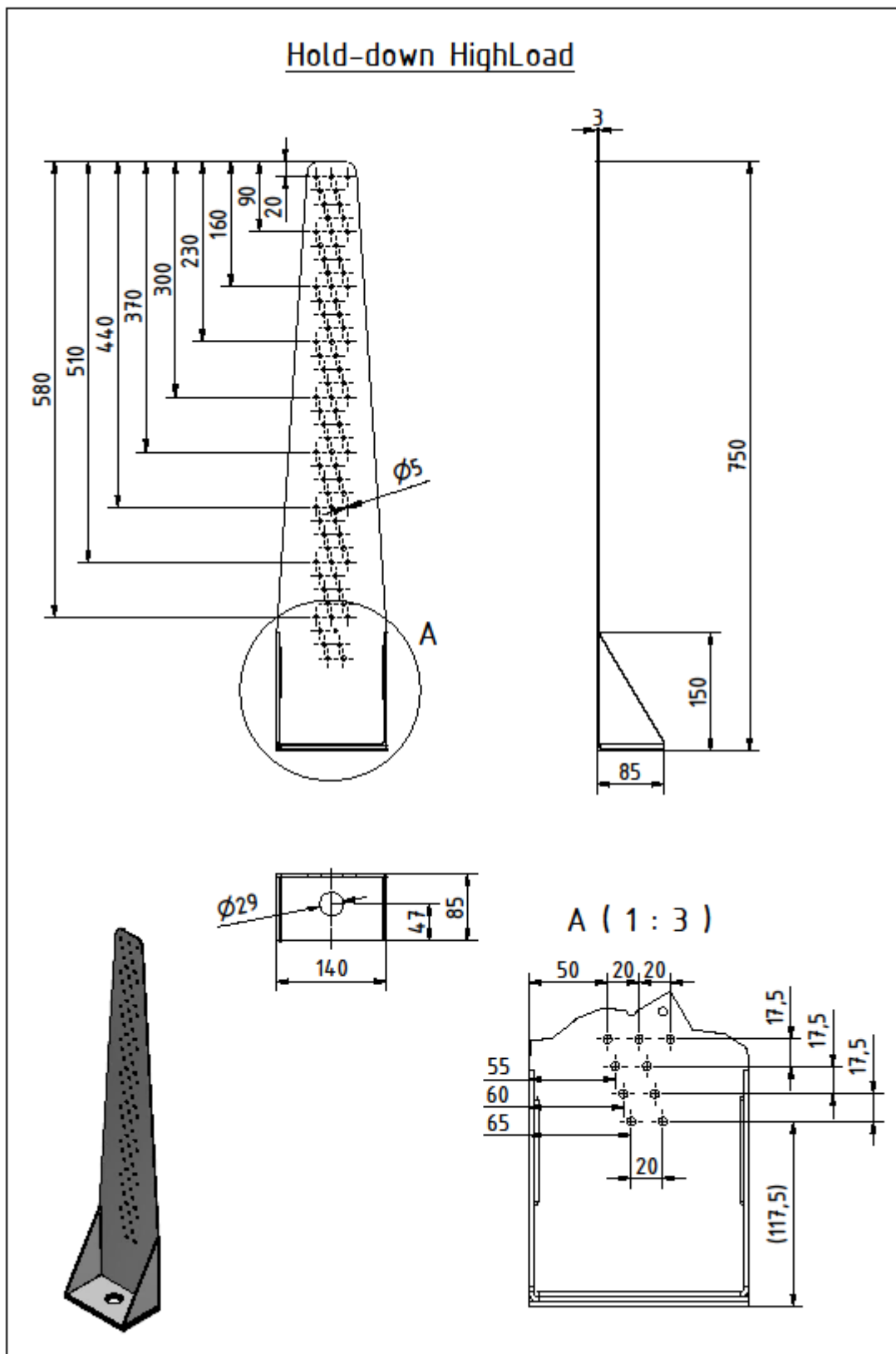

Figure B. 12 Dimensions of Hold-down HighLoad

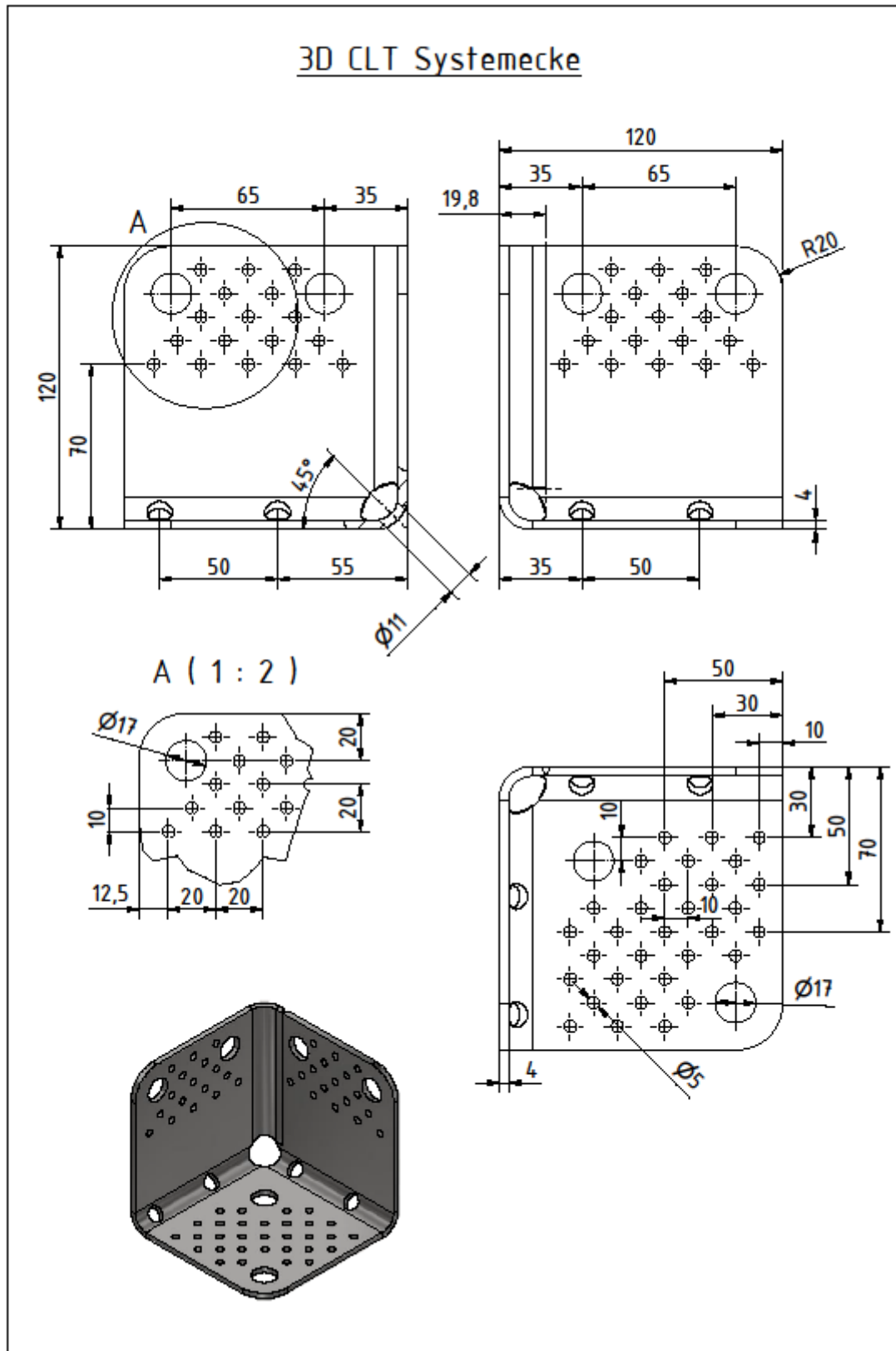

Figure B. 13 Dimensions of 3D Hold-down CLT Innenecke

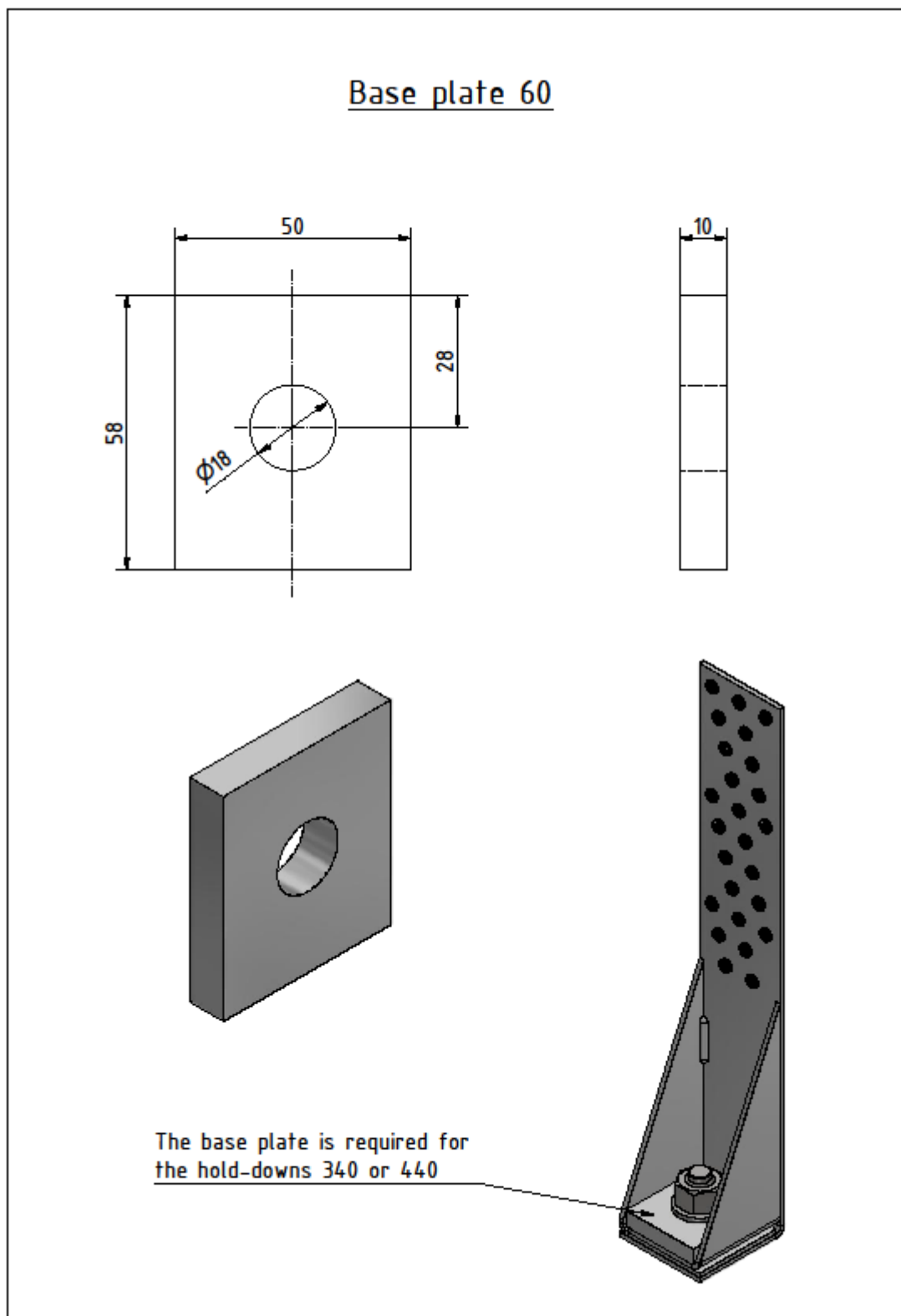

Figure B. 14 Dimensions of Base Plate 60

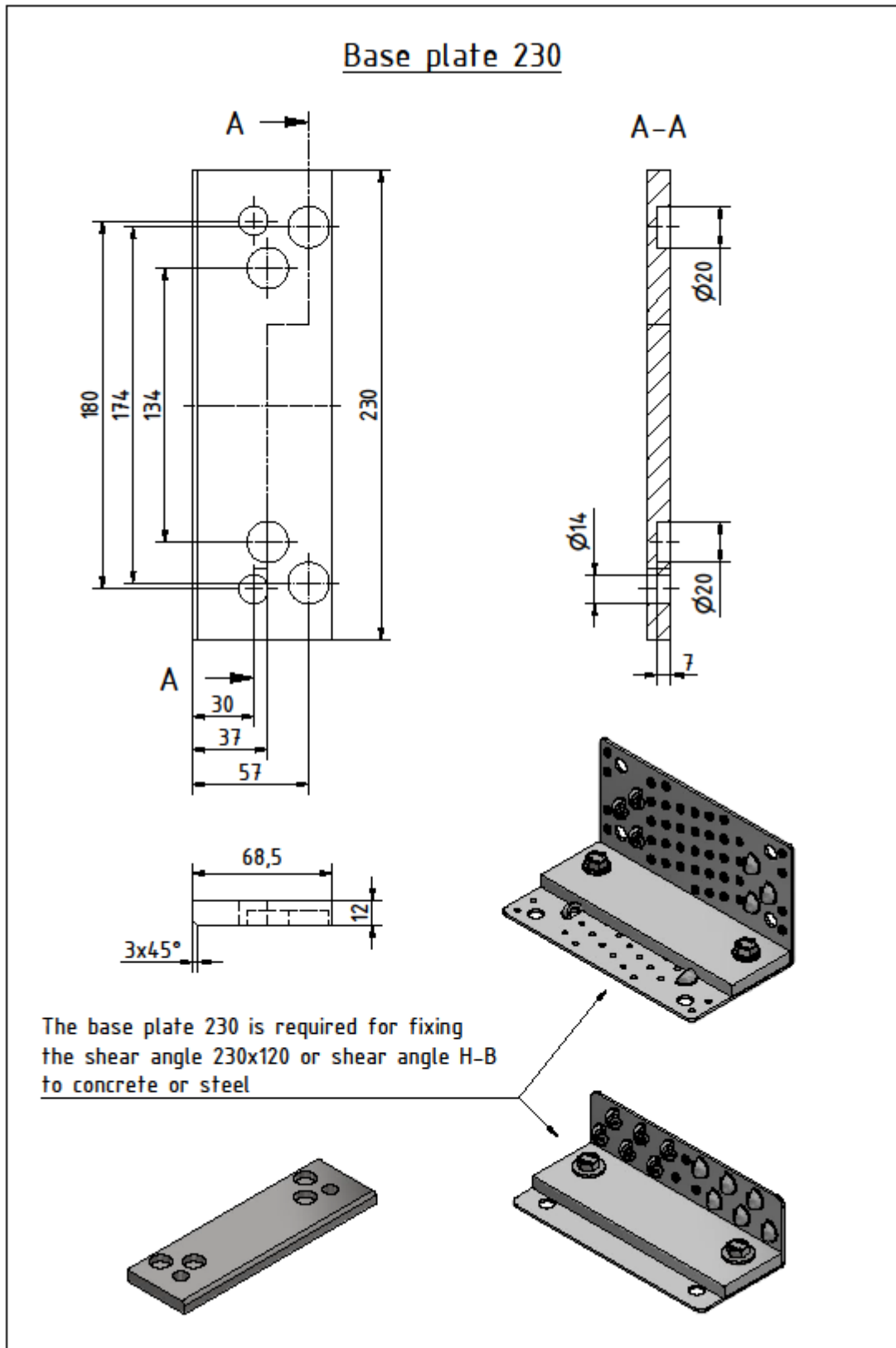

Figure B. 15 Dimensions of Base Plate 230

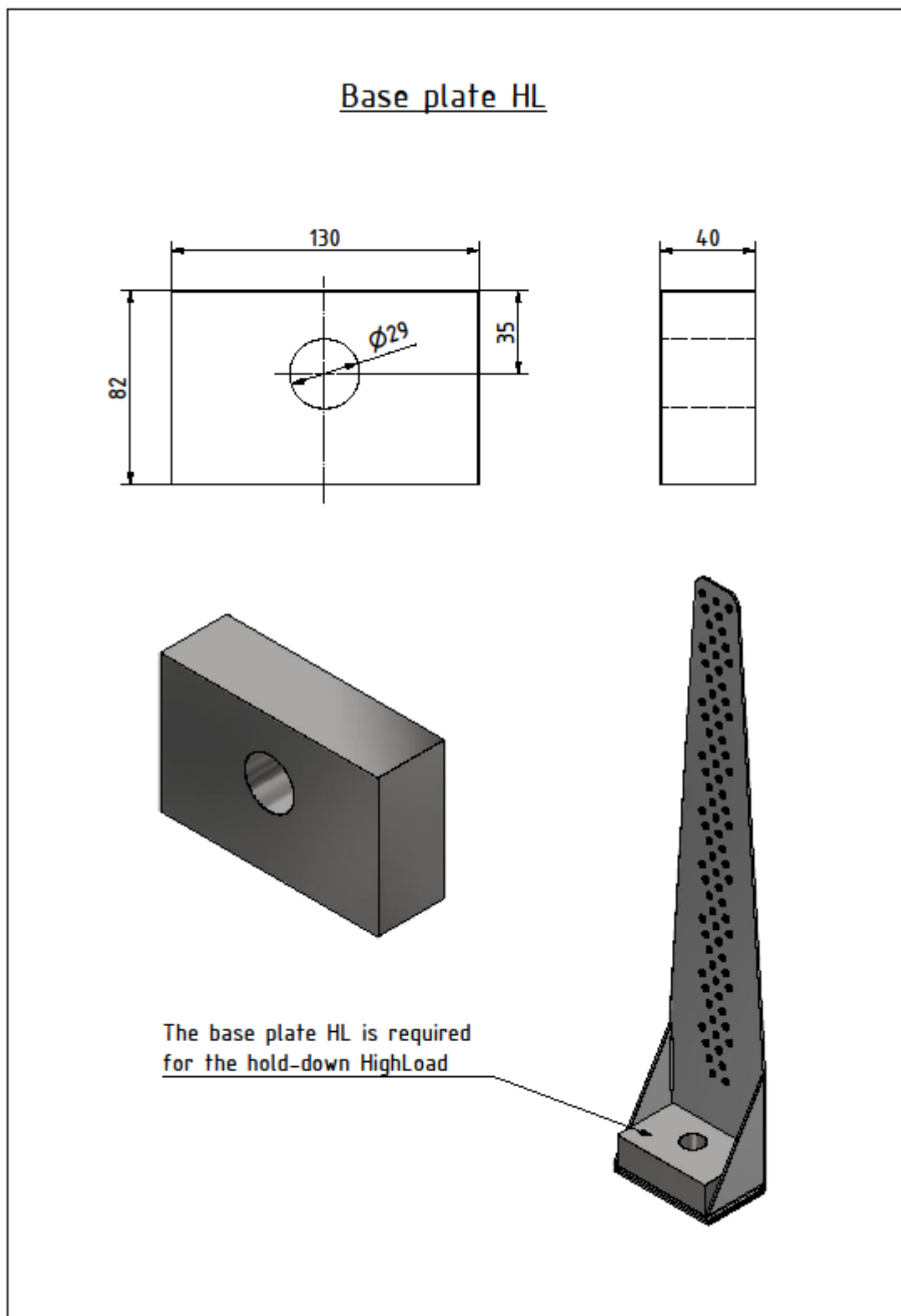

Figure B. 16 Dimensions of Base Plate HL

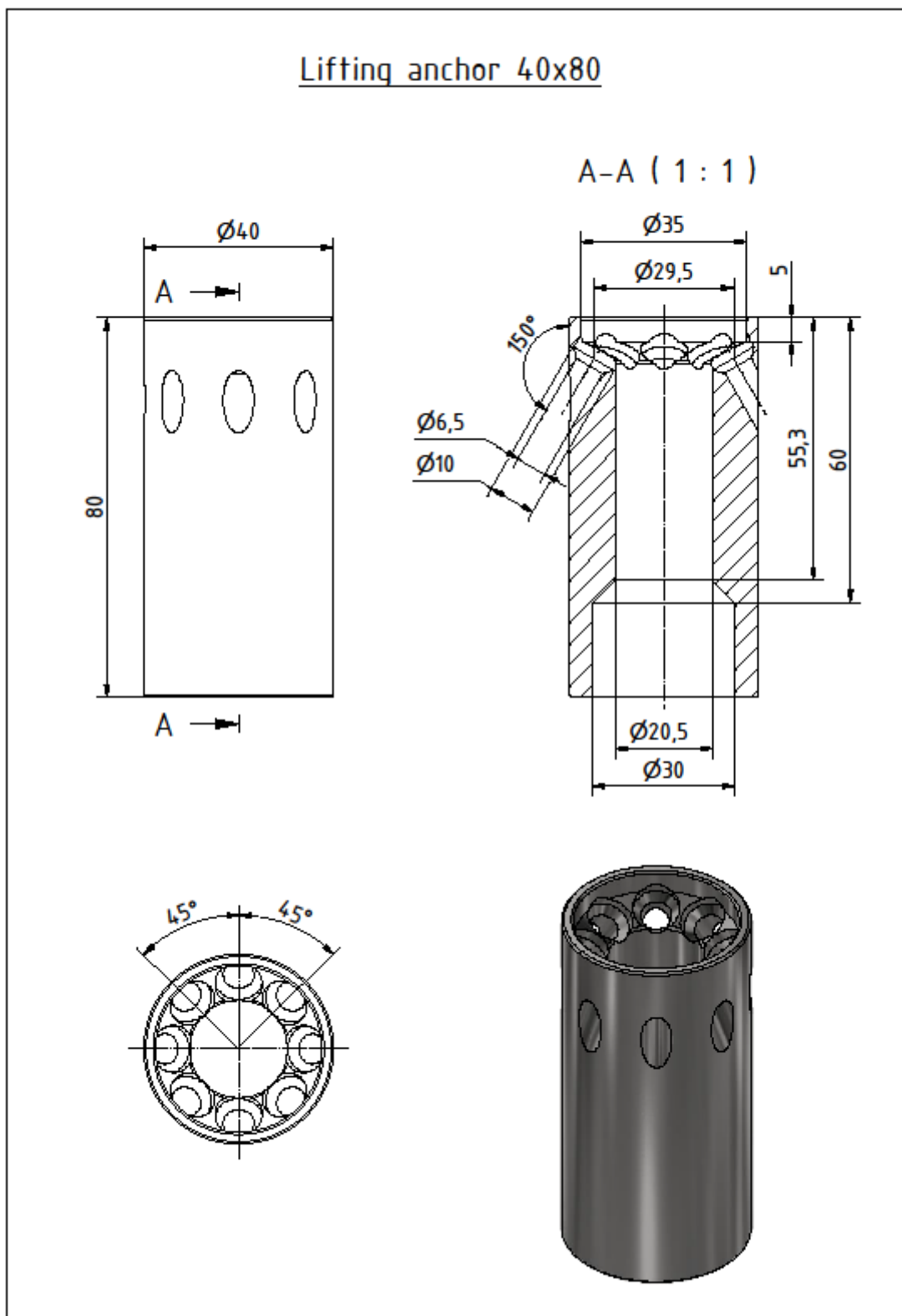

Figure B.17 Lifting anchor 40x80, insertion perpendicular to and flush with member surface

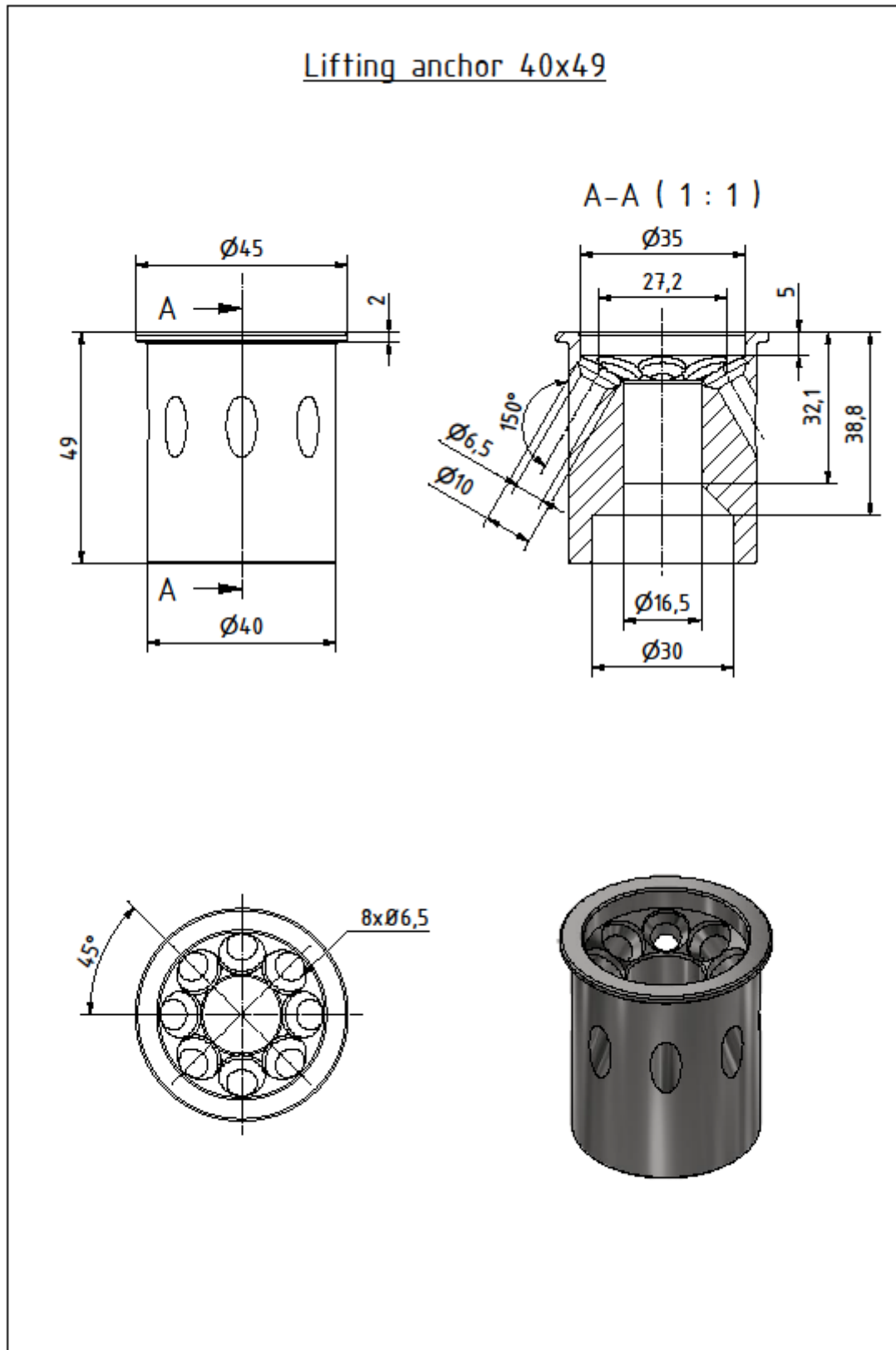

Figure B.18 Lifting anchor 40x49, insertion perpendicular to and flush with member surface

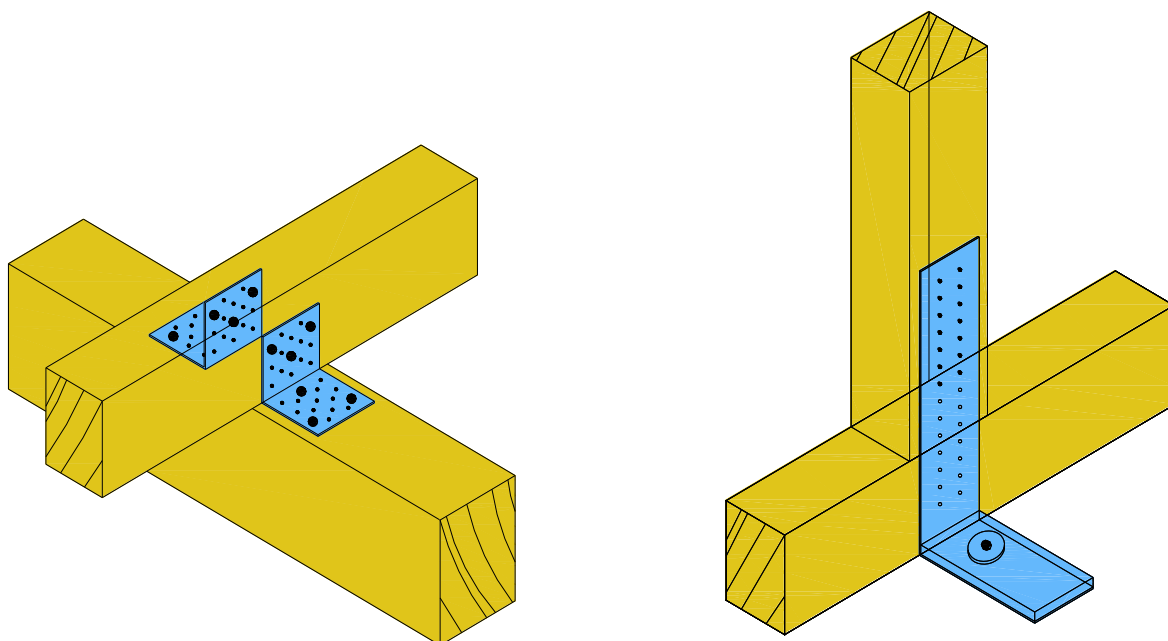

Figure B.19 Typical installation

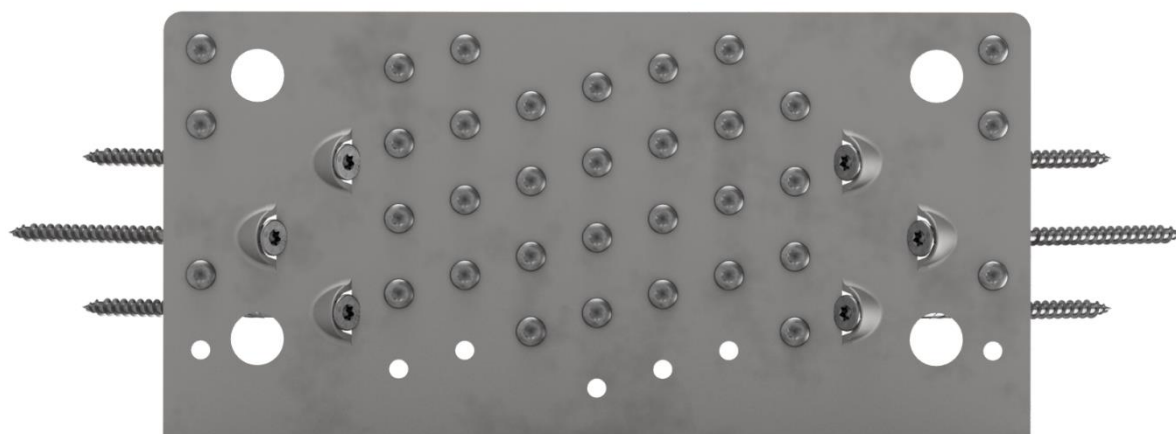

Figure B.20 Fastener Pattern Partial 1 for Shear Angle 240x230 and Shear Plate 230x120 in timber to timber connections (Symmetrical hole-pattern for both flanges)

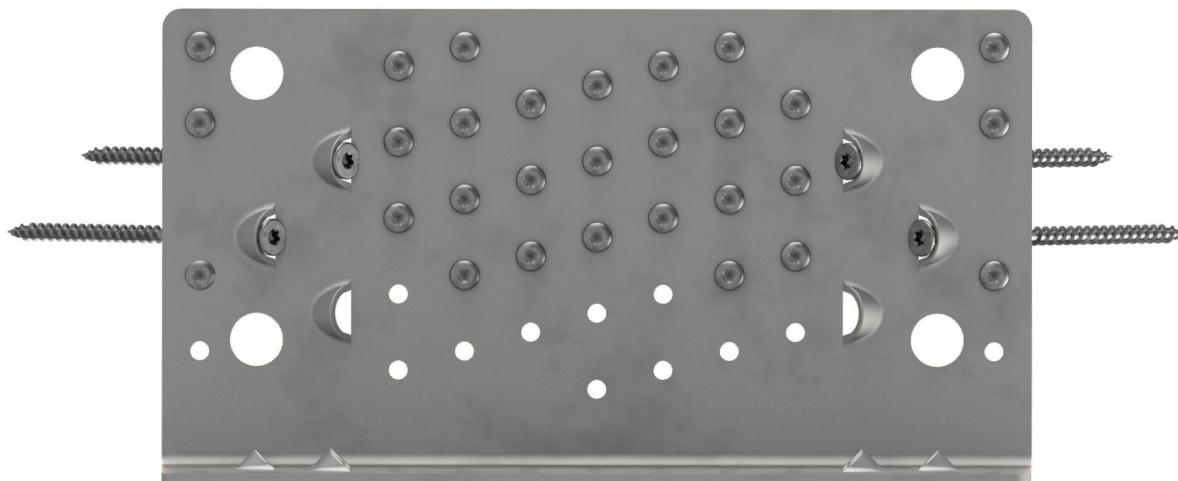

Figure B.21 Fastener Pattern Partial 2 for Shear Angle 240x230 and Shear Plate 230x120 in timber to timber connections (Symmetrical hole-pattern for both flanges)